

Operating manual

Hot Water - High-pressure cleaners

therm CA

11/130

12/150

15/120



Read and conform safety instructions before use!



Description

Dear Customer

We would like to congratulate you on your new hot water high pressure cleaner, and to thank you for buying it!

The following pages contain information about the machine in order to familiarize you with it and facilitate its use.

The machine is a professional cleaning aid in all cleaning tasks, e.g.:

- **facades**
- **flagstones**
- **removing of old paint etc.**
- **vehicles of all types**
- **sheds**
- **machines**
- **containers**
- e.g.: food processing industry**

Technical data	therm CA 11/130	therm CA 12/150	therm CA 15/120
Operating pressure	30 - 130 bar	30 - 150 bar	30 - 120 bar
Nozzle size	25045	25045	25070
Permissible overpressure	145 bar	170 bar	135 bar
Water output ^{(*)1}	max. 660 l/h	max. 720 l/h	max. 900 l/h
Hot water output	12 - 80 °C	12 - 80 °C	12 - 80 °C
Steam level	max. 140 °C	max. 140 °C	max. 140 °C
Heat.oil nozzle/Heat.oil press.	1.35 Gph/10bar	1.35 Gph/11bar	1,5 Gph/10bar
Heat. oil consumpt. (Heat. oil EL)	4.8 kg/h (=5.7 l/h)	5,3 kg/h (=6,3 l/h)	5,8 kg/h (=6,8 l/h)
Heating capacity	49 kW	55 kW	60 kW
Exhaust gas mass flow	0.032 kg/s	0.035 kg/s	0,037 kg/s
Fuel tank	25 l	25 l	25 l
High pressure hose	10 m	10 m	10 m
with hose drum	15 m	15 m	15 m
Electrical rating:	230V / 50Hz / 15A	400V / 50Hz / 6.5A	400V / 50Hz / 7,5A
Input	P1: 3.4 kW	P1: 4.0 kW	P1: 4,0 kW
Output	P2: 2.3 kW	P2: 2.7 kW	P2: 2,7 kW
Weight	150 kg	150 kg	150 kg
Dimens. in mm without reel	790 x 590 x 980	790 x 590 x 980	790 x 590 x 980
Sound level acc. to DIN 45 635	83 dB (A)	89 dB (A)	89 dB (A)
Guaranteed sound level L_{WA}	90 dB (A)	92 dB (A)	92 dB (A)
Vibrations at lance	2.1 m/s ²	2.1 m/s ²	2,2 m/s ²
Recoil at lance	approx. 20 N	approx. 22 N	approx. 24 N

Permissible tolerance for figures $\pm 5\%$ in acc. with VDMA uniform sheet 24411

Description

Connections and functional parts

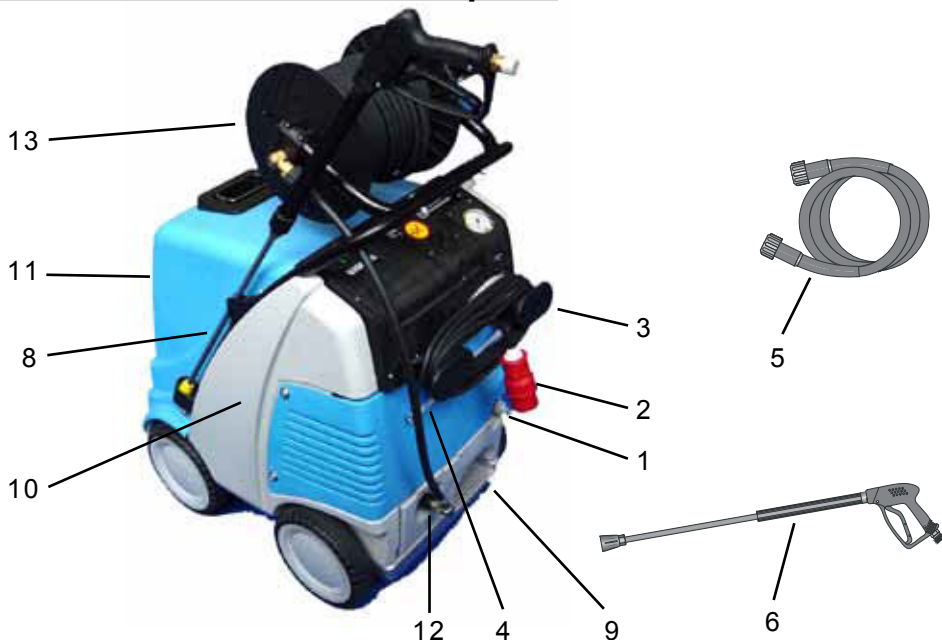

- | | | | |
|---|------------------------------------|----|------------------------------------|
| 1 | Water inlet connection with filter | 8 | Storage bin for spray gun and pipe |
| 2 | Power cable | 9 | Brake |
| 3 | Winder for cable | 10 | Fuel tank |
| 4 | Suction hose for detergent | 11 | Filler aperture for fuel |
| 5 | High pressure hose | 12 | High pressure outlet |
| 6 | Spray gun | 13 | Hose drum (special accessories) |
| 7 | Spray pipe attachment | | |



- | | | | |
|----|-----------------------------------|----|----------------------------|
| 15 | Master switch (appliance On- Off) | 18 | Manometer |
| 16 | (Burner ON- OFF) ignition | 19 | Thermostat |
| 17 | Brief operating instructions | 20 | Detergent dispensing valve |

Description

Water system

The water flows into a tank.

A float valve (a) regulates the water intake.

The water is then directed to the safety spray pipe under pressure from the high pressure pump.

The high pressure spray is formed through the nozzle on the spray pipe.



Detergent and caring system

The high pressure pump can also suck a detergent/caring agent and mix it with the high pressure jet. - The detergent must have the ph-value 7-9 neutral.

Only open the dosing valve, if the chemistry sieve is placed in a liquid.



The rules concerning the environment, refuse and ground water protection must be complied with!

Pressure control and safety facilities

The pressure control valve allows full adjustment of the quantity and pressure of the water.

The safety valve protects the machine from excessive pressure and cannot be adjusted beyond the admissible operating pressure. The setting nuts are sealed with lacquer.



Replacements, repairs, new adjustments and sealing operations may only be performed by trained personnel.

Motor protection switch

The pump motor is protected from overload by a motor protecting switch. In case of an overload the motor is switched off by this motor protecting switch. For a restart the master switch has to be switched off and then on again. In case of a repeated switching off of the motor by the motor protecting switch the cause of the malfunction has to be removed.



Replacement and inspection work may only be performed by trained personnel.

Description

Spray pipe with spray gun

The spray gun only allows the machine to be operated when the safety trigger is pulled.

The spray gun can be used when the safety trigger is pulled. The machine is started and the liquid transported to the nozzle. Spray pressure builds up and quickly reaches the selected operating pressure.

When the trigger is released the gun is closed, which prevents any further liquid from coming out of the spray pipe and the motor is stopped.

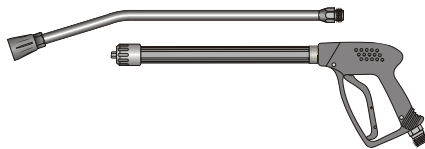

After completing work with your **Kränzle therm CA**, or if work is interrupted, the safety catch (1) must be applied. This makes it impossible to press the trigger by accident.

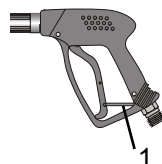

The spray gun is a safety device. Repairs may only be performed by trained personnel. If spare parts are required, use only those approved by the maker.

Thermostat

The thermostat with rotary control switch controls the temperature of the spray water.

Use the rotary control switch to adjust the desired water temperature.



Thermostat with rotary control switch

High pressure hose and spray equipment

The high pressure hose and spray equipment supplied with the machine are made of high quality material specially adapted for the operating conditions of the machine, and are properly marked.

If spare parts are required, only properly marked components approved by the maker should be used. High pressure hoses and spray equipment must be connected so that they are pressure-tight. The high pressure hoses should not be driven over, pulled excessively or twisted. Do not pull the hose over sharp edges, since this will invalidate the warranty.



Description

Heat exchanger

Heating coil: 34 m long - Content: 5 l of water – Heating capacity: 70 k W

The heat exchanger is heated by a high pressure fan heater.

A ventilator (1) draws in the cold, fresh air from the bottom end of the machine and forces it upwards between the outer mantle (2) and the inner mantle (3). In the process, the fresh air is pre-heated and the outer mantle of the heat exchanger is cooled.

The pre-heated air is pressed through a mixing unit (4). Here finely atomized fuel is injected via a nozzle (5) and mixed with the air. The electrodes (6) located below then ignite the fuel-air mixture.

The flame burns from top to bottom, turns round and the hot gas flows past the heating coil (7) on its way back up. The burned gases collect in the exhaust chamber and are emitted from the chimney (8).

The water is forced through a heating coil by the high pressure pump. Hot air flows around the coil, as described above.

The fuel pump (9) draws the oil through a filter (10) and pumps it to the injector nozzle (5). The surplus quantity of fuel flows straight back into the tank. The oil pressure is shown on the fuel manometer (11).

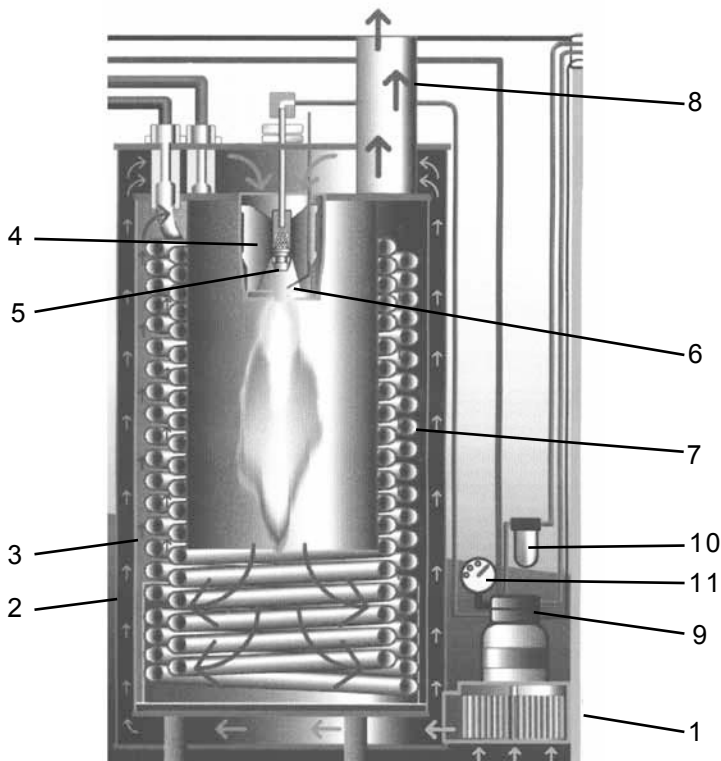

Safety Information

Brake

The Kränzle therm is fitted with a brake that prevents the machine from rolling away on flat ground.

Always apply the brakes firmly when working with the machine !!!

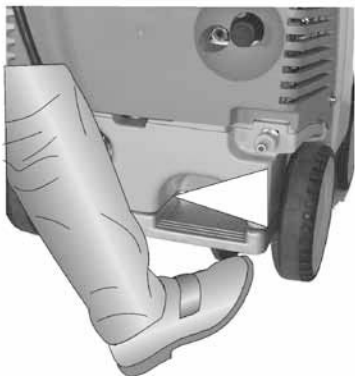

Brake applied

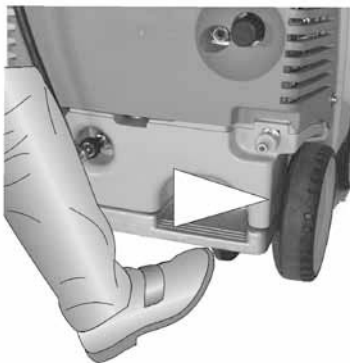

Brake not applied

If you want to move the high pressure cleaner into another direction, first slightly tilt back the machine by pressing the foot rest and pulling the pushbar at the same time.

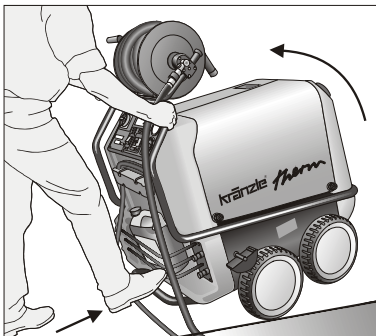

Now you can move the cleaner into the desired direction.

Safety Information



CAUTION !!!

For safety reasons always put the master switch into the „0“ position (=power switch-off) after completion of work.

When starting the cleaning process do not aim the high pressure jet at the object to be cleaned for at least 30 seconds.

It is possible, that the water contents in the combustion chamber (approx. 5 litres) has changed colour due to the resting time.

Safety Information

Important !!!



The machine must be disconnected from the power supply when servicing work is being carried out. The master switch should be in position „0“ and the plug out of the socket.

Do not use the cleaner if electrical connections or other safety-relevant parts (e.g. overpressure valve, high pressure hose, spraying equipment etc.) are damaged.

The machine may only be used by persons who have received the necessary training.

- Never operate the machine without supervision.
- The water spray can be dangerous. It should never be directed at people, animals, electrical apparatus or the machine itself.
- Never direct the spray at power sockets.
- Parts of the machine interior and parts of the gun and lance become hot when hot water is used. Leave the cover of the machine closed when using the machine and do not touch the metallic parts of the gun and lance.
- Children must not use high pressure cleaning equipment.
- Do not damage the cable or repair it incorrectly.
- Do not pull the high pressure hose if there are kinks or loops in it. Make sure that the hose is not damaged on sharp edges.
- Persons operating the machine should wear the necessary protective clothing, i.e., waterproof clothing, rubber boots, safety goggles, headwear etc. It is prohibited to use the machine in close vicinity to people lacking suitable protective clothing.
- The high pressure spray can generate a high level of noise. If noise exceeds the maximum allowed levels, users and others in the vicinity must wear suitable ear protection.
- The high pressure spray causes recoil and additional twisting movement if the gun is angled. The gun must therefore be held firmly with both hands. (see page 2)
- **Do not close off the exhaust aperture on the topside of the machine.** Do not bend over this aperture and do not put your hands inside it. **Exhaust gases are very hot!**
- Do not clamp down the trigger of the gun. Apply the safety catch after use, in order to prevent accidental spraying.
- Do not spray against matter containing asbestos or other hazardous substances.
- Never spray liquids containing solvents, such as paint thinner, petrol, oil, or anything similar. **Note the specifications of the additive makers!** The seals in the machine are not resistant to solvents. The spray vapour of solvents is highly inflammable, explosive and poisonous.

Safety Information

- The machine may not be set up and used in rooms where there is a danger of fire or explosion. The machine may not be used under water.
- Air is required for combustion, and exhaust fumes are generated. If the machine is used in closed rooms, make sure that the exhaust fumes can escape and that there is adequate ventilation.
- Use light heating oil EL (DIN 51 603) or Diesel (DIN EN 590) only. The use of other fuel is perilous and may even cause an explosion.
- Never direct the high-pressure jet at yourself or other persons just to clean clothing or shoes.



**As to the recoil -
see notice on page 2!**

**Apply the safety catch on the
spray gun after each use, in
order to prevent unintentional
spraying!**

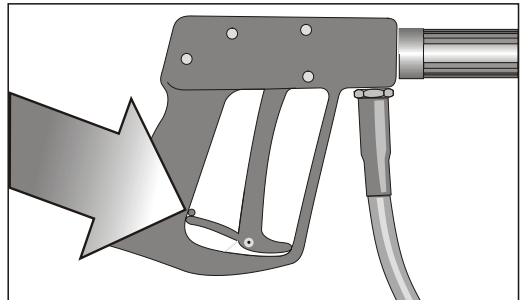

This is prohibited!



Never direct the water jet at people or animals!

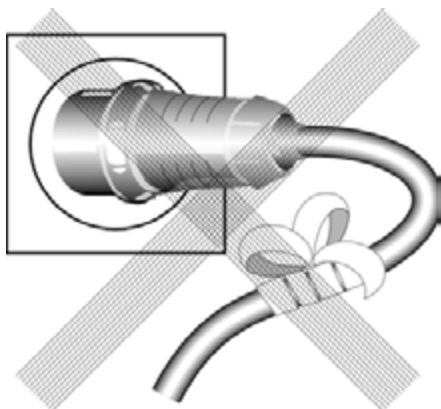

Do not damage the power cable or repair it incorrectly!



**Never pull the high pressure hose if it has formed kinks or "nooses"!
Never pull the hose over sharp edges!**

This is prohibited!



Never allow children to use the high pressure cleaner!

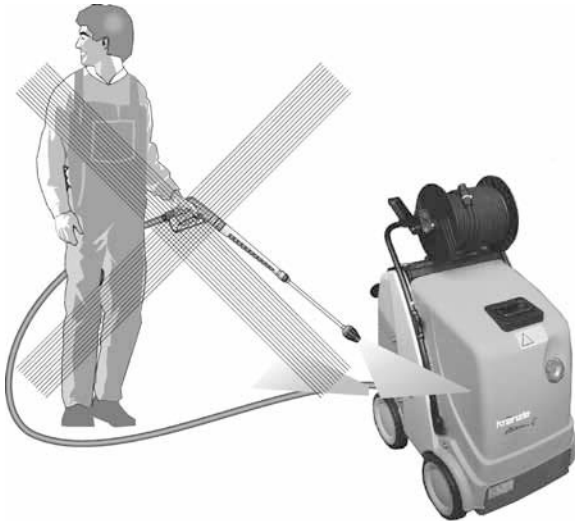

Never direct the water jet at the machine itself!

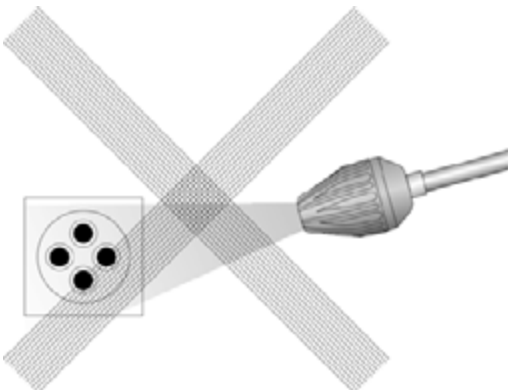

Never direct the water jet at a power socket!

Commissioning

- Secure the machine by applying the brake (see page 8)
- and check the oil level of the high pressure pump.
Do not start the machine if there is no oil on the dipstick. Fill oil if necessary. See page 18.

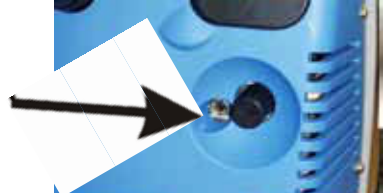

- Fill the fuel tank with light heating oil prior to use.



Use EL heating oil (DIN 51603) or Diesel fuel only.

Unsuitable fuels, such as petrol, may not be used (danger of explosion).

Electrical connection

Make sure that the master switch is switched off (position „0“).

Plug in the power cable of your high-pressure cleaner.

The voltage given on the specification plate must match the mains voltage. You can find the specification plate on the front right-hand side of the appliance.

The machine is supplied with a power cable and plug.



The plug must be connected to a properly installed electrical socket with earthing and have a 30 mA FI residual current circuit breaker. The socket must have a neutral 16A fuse on the mains side.

If an extension cable is used, it must have an earth line that is properly connected to the plug connections. The lines in the extension cable must have a cross section of at least 1.5 mm². The plug connections must be of spray protected design and may not lie on a wet surface. (If the extension cable is longer than 10 m the minimum cross section is 2.5 mm²)

Important!



Extension cables that are too long cause a drop in the voltage and thus interruptions in operation. If you are using a cable drum, the cable must always be fully unwound.

High pressure connection

Connect the high pressure hose to the handgun.

Unwind the hose so that it is free of loops and connect it to the handgun and the machine.



Check that all screw-type connections are pressure-tight. Leaks from gun, high pressure hose or hose drum must be eliminated immediately. Leakage leads to increased wear.

Water connection

Connect the machine to a water tap using a hose of at least 1/2" and turn on the tap. (2-10 bar admission pressure)

The water tank in the machine fills up. When the tank is full, the built-in float valve closes the water inlet.

Use clean water only!

CAUTION !

Please pay attention to the regulations of your waterworks company.

In accordance with EN 61770, the machine may not be directly connected to the public drinking water supply lines.

A brief connection however is permissible according to DVGW (German Association for Gas and Water Affairs) if a tube ventilator with check valve (Kränzle Order-No. 41.016 4) is built into the water supply.

Also indirect connection to the public drinking water supply lines is permissible by way of free emission in accordance with EN 61770, e.g. by using a reservoir with a float valve.

Direct connection to a non-drinking water supply line is permissible.

Commissioning



- Switch off the ignition. Rocker switch (16) to „0“.
- Set the pressure control (4) valve to maximum pressure (see below) and close the detergent valve (20).
- Open the gun and switch the master switch (15) on.

The high pressure pump now presses the air out of the lines, and after a short time the high pressure spray is formed and the operating pressure is reached.

If the system has to be deaerated (appliance rattles), open and close the spray gun repeatedly.



4

CAUTION



After an extended standstill do not instantly aim the high pressure water jet at the object to be cleaned, as the remaining water inside the high pressure cleaner may be discoloured.

Adjusting the pressure

Use the pressure control valve (4) directly on the pump head to adjust the pressure.



The machine is fitted with a Total-Stop-System.



If the main switch is switched on, the motor is started by means of a pressure switch as soon as the gun is operated. The pump quickly reaches the set operating pressure. When the gun is closed the motor is cut off immediately.

Usage as a cold water high pressure cleaner

- Leave the ignition „OFF“. Rocker switch (1A) to „0“.
- Start cleaning

Usage as a hot water high pressure cleaner

- Set the target temperature on the thermostat to min. 40 °C and then switch the ignition „ON“ (rocker switch). The oil burner starts to work. The water is heated up and kept at the temperature you have set.

During high-pressure operation (above 30 bars) the temperature may not exceed 90 °C.

Steam level

To reach the steam level, i.e. over 90 °C water temperature, adjust the pressure and the water quantity downwards using the handwheel (4) and choose the desired temperature of max. 150 °C with the thermostat. For high pressure cleaners with hose drum applies: The hose must always be fully unwound.

During steam operation the pressure may not exceed 30 bars.

Usage with detergents

- The detergent must have the ph-value 7-9 neutral.
- Wait until the pump has pressed the air out of the lines.
- Put the chemical filter into a container with detergent.
- Open the detergent valve (20). The pump now sucks detergent in and mixes it with the high pressure spray.
- Set the desired concentration of detergent.
- **At the end of the working procedure with detergent reset the rotary button to „0“.**
- **When the high pressure cleaner is operated with open chemistry valve without chemicals, the pump sucks in air. Damages caused to the pump as a result are not covered by the guarantee.**

Comply with additive manufacturers' instructions (e.g. protective equipment and waste water regulations). Use only additives approved for use with high pressure cleaners. Using other additives impairs the safety of the machine.

In the interest of the environment and to keep expenditure down, we recommend sparing use of detergent. Please observe the recommendations of the detergent manufacturer.

After using detergents, rinse the machine for approx. 2 minutes by pressing the trigger of the spray gun.



Decommissioning

- Switch off the master switch (position „0“).
- Pull the plug out of the power socket.
- Turn off the water supply.
- Open the gun until the pressure is gone.
- Lock the gun.
- Disconnect the water hose.
- Slacken the connections of the high pressure hose and gun and unscrew the high pressure hose from the machine (appliances without hose drum).

Anti-Freeze Protection

The machine is normally still partially filled with water after work has been completed. It is therefore necessary to take special precautions to protect the machine from frost.

- **Completely empty the machine of water**

Disconnect the machine from the water supply and switch off the ignition. Switch on the master switch and open the gun. The pump now presses the remaining water out of the heating coil. Do not allow the machine to run for longer than a minute without water.

- **Fill the machine with anti-freeze**

If the machine is not in use for lengthy periods of time, it is advisable to pump anti-freeze into the machine, especially in winter. For this purpose, fill the antifreeze agent into the water box and turn on the machine without ignition (rocker switch (16) to „0“). Wait with opened gun, until the agent comes out of the nozzle.

However, the best protection against frost is to keep the machine in a place that is safe from frost.

Care and Maintenance

Care and maintenance is required to keep the machine in good working order, and to allow you to enjoy the machine for as long as possible.



IMPORTANT!!!

Always remove the plug before working on the machine!

Only use original Kränzle spare parts

What to do!

- Weekly, or after approx. 40 hours of operation

- Check the oil level of the high pressure pump. (see page 13)
If the oil level is too low, add oil until the oil level is between the two markings on the oil measuring rod.

Change the oil (see page 19) if it has a grey or whitish appearance. The oil should be disposed of responsibly.

- Check the filter in front of the float valve in the water tank and the fuel filter in front of the solenoid valve. Clean the filters if necessary.

- Yearly, or after approx. 500 hours of operation

- Desulphurise and decarbonize the heating coil.
- Check if the heating coil is calcified (see page 20).
- Check the oil burner and ignition system.
Clean the oil nozzle, oil filter, solenoid valve and filter, clean and adjust the ignition transformer, ignition cable and ignition electrodes and replace defective
- Change the oil

Changing the oil

To do this, take the oil drainage hose (1) connected to the oil drain screw, from the inside of the machine and open the red oil filler cap on the top side of the black oil reservoir. Open the cap at the end of the hose. Drain off the oil into an oil pan and dispose of it responsibly.

Close the end of the hose.

Refill with oil.

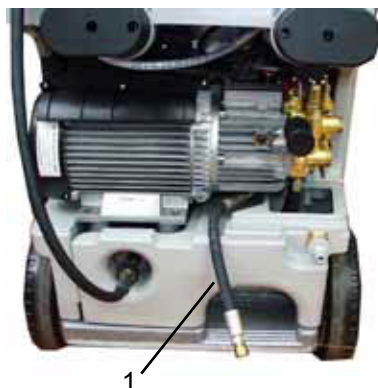

Oil leakage



If oil leaks out, go to the nearest customer service (dealer) immediately. (Environmental damages, transmission damages, loss of guarantee.)

Type of oil: **Formula RS of Castrol - Quantity: 1.0 l**

Adjusting ignition electrodes

For a smooth ignition, the setting of the ignition electrode must be controlled regularly.

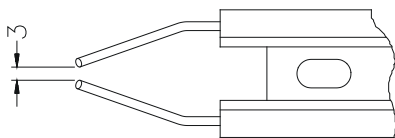

Check distance in mm

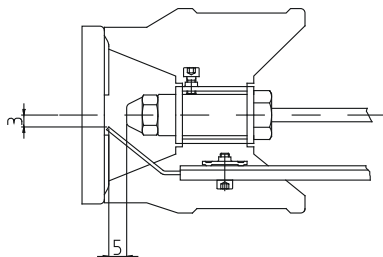

Fuel System

Your fuel may contain particles of dirt, or impurities or water may get into the tank during refuelling.

As a safeguard for the fuel pump the appliance is fitted with a fuel filter (c). Check regularly if the filter is soiled and clean it if necessary.

Check the tank for impurities on a regular basis.

Empty the fuel tank using the drainage screw (d) at the bottom of the tank. Clean the tank and the fuel lines carefully. Screw in the drainage screw.



Detergent and dirty fuel must be disposed of responsibly.

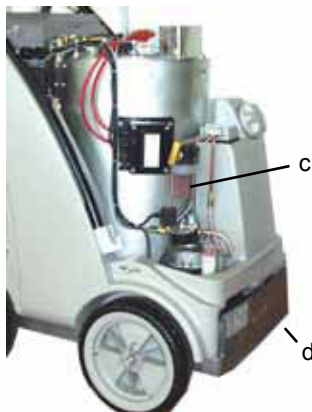

Decalcifying the heating coil

Calcified machines use an unnecessary amount of energy because the water can only be heated slowly and the excess pressure valve feeds a part of the water back into the pump circuit.

Calcified machines can be recognised by increased pipeline resistance.

Check pipeline resistance by disconnecting the high pressure lance from the gun and switching the machine on. A full jet of water emerges from the gun. The machine must be decalcified if the pressure shown on the manometer is greater than 25 bars.

Decalcifiers are caustic!



Observe the instructions for usage and accident prevention. Wear protective clothing to prevent the decalcifying agent from contacting your skin, eyes and clothing (e.g. gloves, safety mask etc.)

Proceed as follows to decalcify the machine:

- Unscrew the high pressure hose from the machine and decalcify it separately.
- Put the detergent suction hose into a container of decalcifying solution.
- Set the dispenser valve to the maximum concentration.
- Switch on the machine.
- Hold the gun in a separate container and press the trigger.
- Wait for about a minute until the decalcifier comes out of the gun (recognisable by its whitish colour).
- Switch off the machine and allow the solution to act for about 15-20 minutes.
- Switch the machine back on and rinse it through with clear water for about 2 minutes.

Now check whether pipeline resistance is back to an acceptable level. Repeat the decalcifying process if the pressure without the high pressure lance is still above 25 bars.

Rules, directives, inspections

● Inspections performed by Kränzle

- measurement of earth line resistance
- measurement of voltage and current
- inspection of tension consistency with +/- 1530 V
- pressure check of heating coil at 300 bar
- visual and functional check as per the inspection sheet provided
- exhaust fume analysis (see test strips provided)

● Guidelines for liquid sprayers

The machine conforms with the „Guidelines for liquid sprayers“. These guidelines are issued by the organisation of trade associations and may be obtained from Carl Heymann-Verlag KG, Luxemburger Str. 49, 50939 Köln. These guidelines specify that this machine is to be inspected by qualified personnel whenever necessary, but no less than once every 12 months. These inspections must be recorded in the inspection log at the end of this manual.

● Pressure container and steam boiler directives

Kränzle high pressure cleaning equipment conforms to the pressure container and steam boiler directive. No construction approval, notification of licence and takeover inspection are required. The water capacity is less than 10l.

● Duties of owner

The owner is to ensure that all safety-relevant components are in a serviceable condition before the sprayer is used. (e.g., safety valves, hose and electric cables, spray equipment etc).

● Emission control legislation

With stationary installation, the emission levels of the machine must be checked once a year by a qualified organisation or person according to German law. The first inspection must be carried out four weeks after the machine is commissioned. The owner is responsible for having the inspection performed.

Description of function - Troubleshooting



IMPORTANT!!!

Always remove the plug before working on the machine!

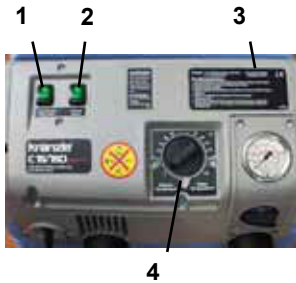

- 1 Master switch
- 2 Ignition "ON/OFF"
- 3 Brief operating instructions
- 4 Thermostat



- 5 Hand wheel for pressure adjustment
- 6 High pressure pump
- 7 Pressure switch black (start solenoid valve)
- 8 Pressure switch red (start pump)
- 9 Safety valve

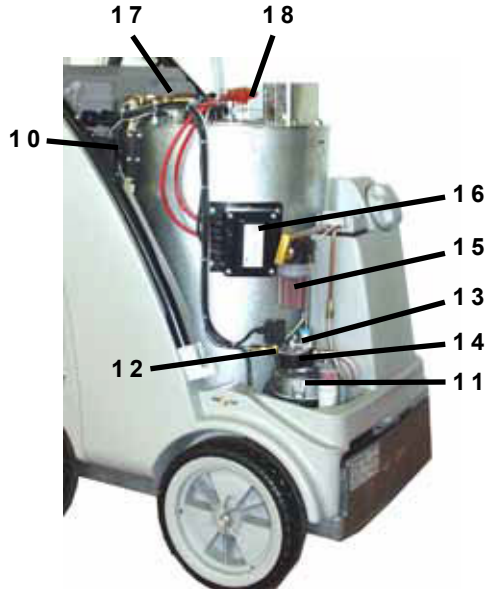

- 10 Flow controller
- 11 Motor for ventilator and fuel pump
- 12 Solenoid valve (Fuel)
- 13 Fuel pump
- 14 Fuel manometer
- 15 Fuel filter
- 16 Ignition transformer
- 17 Thermosensor water
- 18 Ignition electrodes

Description of function - Troubleshooting

Cold water mode

1. Connect to water supply and determine whether the water tank fills up completely and the float valve stops.
2. Ignition (2) to OFF.
3. Main switch (1) to ON.
4. Open high pressure gun. The appliance started, the pump sucks water from the water tank and moves the water through the heating coil to the lance, the pressure is increased.



ATTENTION!!

If the pressure is not built up immediately, there is still air in the pump. Open and close the gun repeatedly to press the air from the machine.

Hot water mode

Start the machine just like in cold water mode and then turn the rocker switch (2) for the burner to ON. Then, turn the rotary switch on the thermostat, (4) located on the front, to the desired temperature (at least 40 °C) in order to activate the burner, i.e., that fuel is injected.

The manometer (14) on the fuel pump shows approx. 10 bars. If this reading is not displayed, check whether

1. there is heating oil in the tank
2. the motor fuse (11) in the switch box (below the operation panel) has tripped.
3. the fuel sieve (15) or the fuel sieve in the pump (13) is dirty.
4. the fuel pump does not operate smoothly or is blocked.
5. the ventilator jams.

The thermostat grants permission to open the solenoid valve. The burner starts and heats up the water to the set temperature. The burner switches off as soon as the desired temperature has been reached.

If the temperature drops again, the burner switches on automatically thus guaranteeing the required constant temperature.

Description of function - Troubleshooting

The thermostat (4) is controlled via a thermo-sensor (18) mounted at the outlet of the heating coil.

In the switchbox (below the operating panel), a fuse (F1) is installed on the board protecting the motor (11) of the fuel pump and the ventilator. If the motor is overloaded the fuse trips. This may happen if the fuse pump is blocked or sluggish - the same applies if the ventilator is blocked or sluggish or in case of an electrical malfunction.

Another fuse (F2) on the board trips, if the ignition transformer (17) is faulty.

To avoid an overheating of the burning chamber a flow indicator (10) is installed in the high pressure system between the high pressure pump (6) and the burning chamber enabling a fuel supply only if water streams through the heating coil at the same time.

Control board (p. 28-29)

The control board is equipped with two LEDs for trouble shooting.

L1: - permanently illuminated, if the overcurrent release has tripped.

- blinking, if the fuel flow valve detects only a low quantity of fuel in the tank or if it is defective.

L2: - illuminated, if the burner has been released but the flame is not burning. If the flame starts burning within 2 seconds, the LED goes out.

If the LED does not go out the combustion has to be checked. If the LED is not illuminated at all, the flame sensor has to be checked.

Nevertheless the cleaner can be used as a cold water high pressure cleaner even if the burner is switched off.

Troubleshooting



IMPORTANT!!!

Always remove the plug before working on the machine!

<i>Malfunction</i>	<i>Cause of malfunction / Trouble shooting</i>
<p>Water supply</p> <p>Water tank runs over.</p> <p>Water tank does not fill completely.</p> <p>Pump does not suck.</p> <p>Test: check water and chemical system for tightness.</p>	<p>Float valve is dirty. Float valve is defect.</p> <p>Float valve is defect Water filter soiled. Check water inlet quantity.</p> <p>Valves stick or are dirty. Suction hose leaks. Chemistry valve is open or leaks. Check hose clips (connections). High-pressure nozzle is clogged.</p> <p>Connect water inlet directly to the pump (2-4 bar pre-pressure). Disconnect suction lines below the pump.</p>
<p>High-pressure pump</p> <p>Pump makes lots of noise. Operating pressure is not reached.</p> <p>Water drops from the pump.</p> <p>Oil drops from the transmission.</p> <p>Pressure is too low</p>	<p>Pump sucks air. Check suction connections. Check high-pressure nozzle. Check valves. Check O-rings under valves. Check sleeves. Manometer is defect. Unloader: check stainless steel seat and ball. Check seals on the control piston.</p> <p>Replace sleeves in the pump. Replace O-rings.</p> <p>Check oil seals (replace). Check plunger and plunger guides. Check water supply, since water deficiency or air suction can cause damage to seals and O-rings (chemistry valve leaks?).</p> <p>Worn high pressure nozzle</p> <p>Stainless steel seat, ball, O-ring in unloader is dirty or defect.</p> <p>Manometer is defect</p>

Troubleshooting

<i>Malfunction</i>	<i>Cause of malfunction / Trouble shooting</i>
<p>Machine does not switch off</p> <p>Test: Jumper (red) pressure switch</p>	<p>Check return body and O-ring in unloader of the valve housing.</p> <p>Check pressure switch (red).</p> <p>Check micro switch.</p> <p>Check cable connections.</p> <p>Board is defect.</p>
<p>Appliance does not start or stopps during operation</p>	<p>Check electricity supply.</p> <p>Check main switch.</p> <p>Check cable connections.</p> <p>Check board.</p> <p>Check pressure switch.</p> <p>Switch off by overcurrent release.</p>
<p>Heating (burner)</p> <p>Fuel pump/blower operates, but burner does not heat.</p> <p>Fuel pump/blower does not operate.</p> <p>- Pump makes lots of noise - Fuel operating pressure has not been reached</p> <p>Coupling between burner motor and fuel pump is broken</p>	<p>Set water temperature is reached.</p> <p>Increase temperature on thermostat with rotary control switch.</p> <p>Open gun, until temperature drops.</p> <p>Fuel tank is empty.</p> <p>Fuel filter is dirty.</p> <p>Fuel nozzle is dirty.</p> <p>Blower/fuel pump motor is defect.</p> <p>Check electrical equipment.</p> <p>Check fuse in terminal box.</p> <p>Coupling between burner motor and fuel pump is defect.</p> <p>Water in fuel tank.</p> <p>Dirt or rust in the fuel pump.</p> <p>Clean tank.</p> <p>Replace fuel pump.</p>
<p>Burning</p> <p>Smoke during operation</p> <p>Smoke after switching off</p>	<p>Fuel is dirty.</p> <p>Nozzle or nozzle stock leaks.</p> <p>Water in tank.</p>

Troubleshooting

<i>Malfunction</i>	<i>Cause of malfunction / Trouble shooting</i>
<p>Solenoid valve on the fuel pump does not open Test: Pressure switch (black) Bridge in terminal box between terminal 3 +4 Test: Connect solenoid valve 230 V externally Oil pressure on the fuel pump is too low too high</p>	<p>Check pressure switch (black). Solenoid valve is defect or dirty. Clean filter, clean supply line, clean fuel pump. Setting is wrong. Clean fuel nozzle, or replace it.</p>
<p>Ignition does not function</p>	<p>Check ignition cable. Charring of plug-in contacts by moisture. Cable is broken Check ignition transformer connections. Transformer is defect Ignition electrode has been falsely set or burnt up.</p>
<p>Ventilator does not operate</p>	<p>Blower-/fuel pump motor is defect. Check electrical equipment. Check fuse in terminal box. Coupling between burner motor and fuel pump is defect.</p>
<p>Spray gun - High-pressure hose Gun drips High pressure hose drips Nozzle is clogged</p>	<p>Check for leakages. Replace seals. Replace O-ring under screwed connection. Manometer indicates pressure, but no water comes out of HP-hose – clean nozzle.</p>
<p>Sucking detergent Detergent is not sucked</p>	<p>Pump sucks air. Check hose clips. Test: Connect water line to the pump. Water inlet: 2 - 4 bar pre-pressure. No water must come from the detergent hose.</p>

Pipeline plan

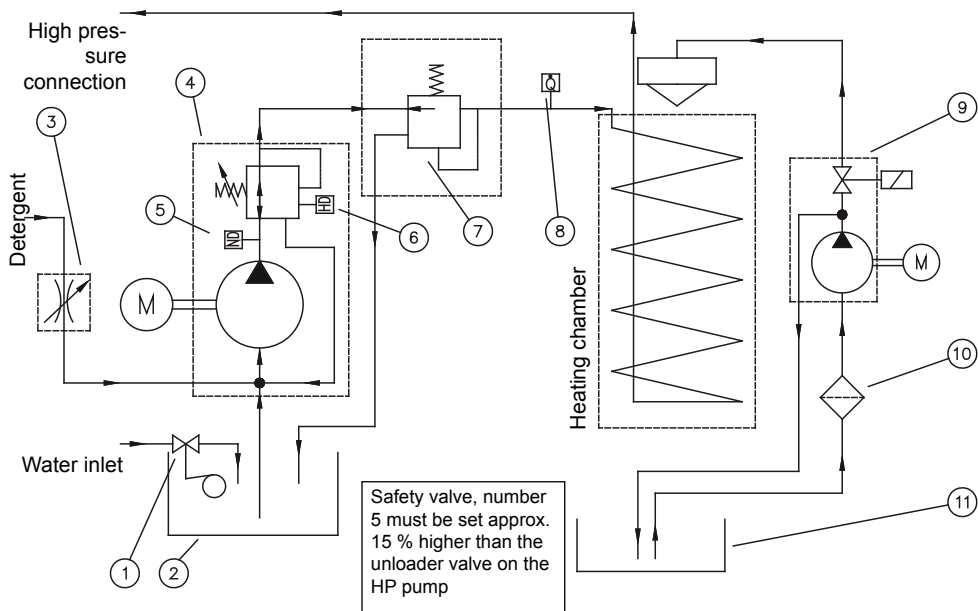

- | | |
|------------------------------------|----------------------------------|
| 1 Float valve, water inlet | 6 Pressure switch Burner release |
| 2 Water tank | 7 Safety valve for heating coile |
| 3 Control valve, detergent | 8 Flow controller |
| 4 High pressure pump | 9 Fuel pump with solenoid valve |
| 5 Pressure switch Motor Start/Stop | 10 Fuel filter |
| | 11 Fuel tank |

Guarantee

The guarantee is only valid for material and manufacturing errors. Wearing does not fall within this guarantee.

The instructions in our operating manual must be complied with. The operating instructions form part of the guarantee. The Guarantee is void if other parts are used than genuine Kränzle accessory parts or genuine Kränzle spare parts.

For high-pressure cleaners sold to the user the guarantee period is 24 month.

For high-pressure cleaners sold for industrial use the guarantee period is 12 month. In the case of a guarantee please contact your dealer or authorized seller delivering accessories and your purchase receipt. You can find them in the internet under www.kraenzle.com.

The guarantee is also void if the machine is used with exceeding the temperature and speed limits, a voltage below the required rating, with less than the required amount of water or with dirty water. Pressure gauge, nozzle, valves, sleeves, high pressure hose and spray equipment are wear parts and are not covered by the warranty.

Circuit diagramme 230V / 50Hz

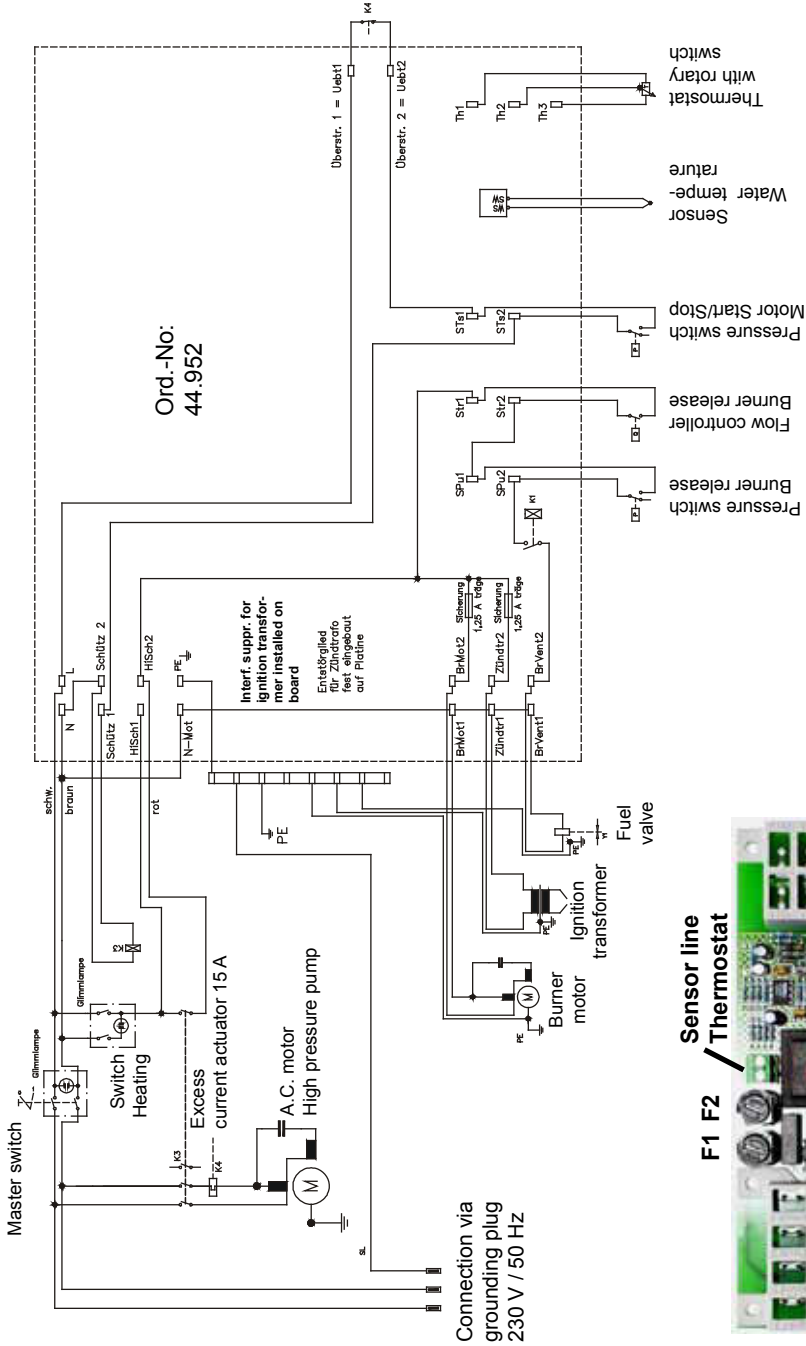

Flow controller
 Pressure switch
 Burner release
 Motor Start/Stop

F1 F2
 Sensor line
 Thermostat



Circuit diagramme 400V / 50Hz

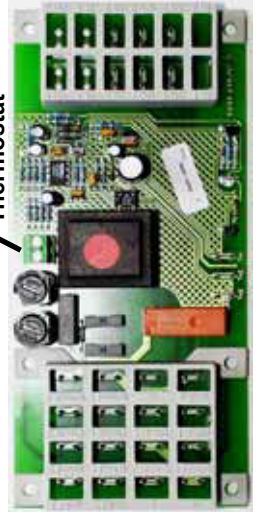
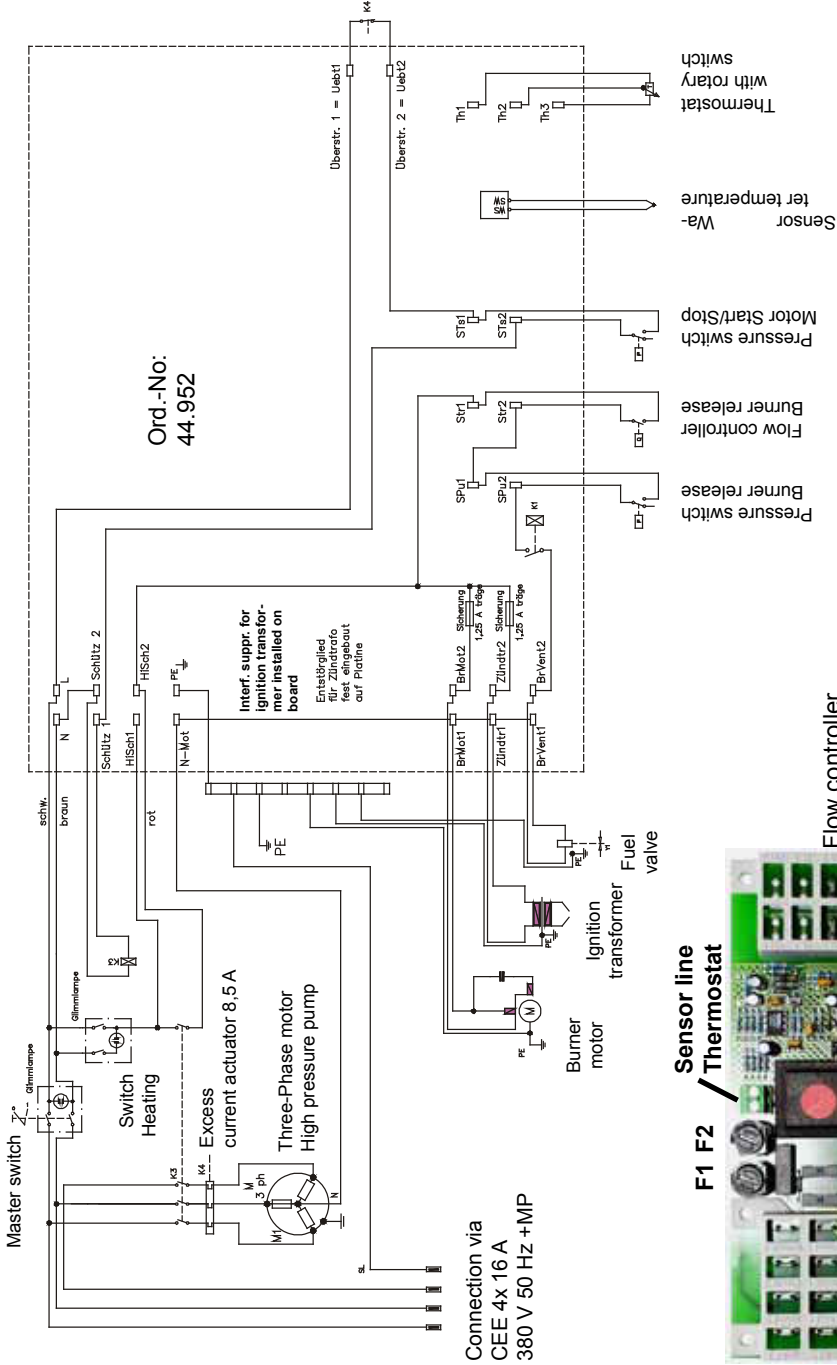

Complete Assembly

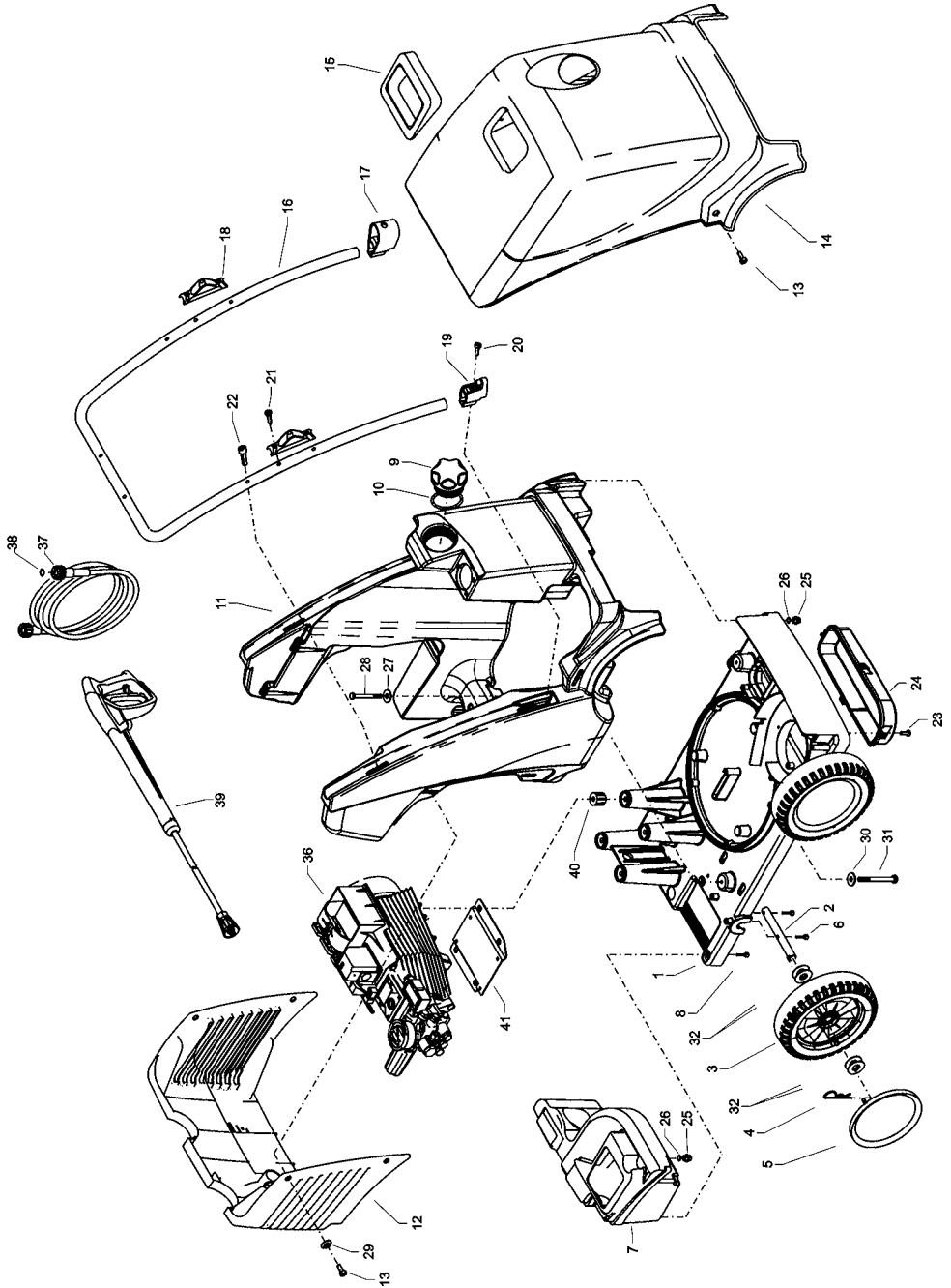

Spare parts list KRÄNZLE therm CA Complete Assembly

No.	Description	Order No.	No.	Description	Qty.	Order No.
1	Fahgestell	44.800	22	Schraube M6x35 DIN6912	2	46.024
2	Achse	44.820	23	Schraube M5x16 DIN7985	4	40.178
3	Rad d250	46.010 2	24	Deckel Zuluft	1	44.801
4	Federstecker	40.115 1	25	Ablassschraube	2	44.004 1
5	Radkappe	46.011	26	Dichtung für Ablassschraube	2	41.047 1
6	Schraube M6x30 DIN912	43.037	27	Scheibe DIN9021 8,4	4	41.409
7	Wasserkasten schwarz	44.805 1	28	Schraube M8x80 DIN931	4	44.832
8	Schraube M6x16 DIN912	44.831	29	Scheibe Haubenbefestigung	6	44.849
9	Tankdeckel mit Pos. 10	44.833	30	Scheibe DIN9021 8,4	4	41.409
10	O-Ring 70 x 5	44.020	31	Schraube M 8 x 110 DIN931	4	44.826
11	Brennstofftank schwarz	44.806 1	32	Scheibe D40x19x1,5	16	46.533
12	Haube hinten	44.812	36.1	Motor-Pumpe für therm CA 11/130	1	44.960
13	Schraube M5x14 DIN7985	40.536	36.2	Motor-Pumpe für therm CA 12/150	1	44.961
14	Haube vorn	44.813	36.3	Motor-Pumpe für therm CA 15/120	1	44.962
15	Kaminblende	44.825	37	Hochdruckschlauch NW 8 10 m	1	44.878
16	Schubbügel	44.834	38	O-Ring 9,3 x 2,4 Viton	2	13.273 1
17	Köchertopf	46.503	39	M2000-Pistole einteilig mit Düsenschutz und HD-Düse 25045 (CA 11/130; CA 12/150)		12.486-D25045
18	Lanzenhalter	42.610	39.1	M2000-Pistole einteilig mit Düsenschutz und HD-Düse 2507 (CA 15/120)		12.486-D2507
19	Lanzensteränder	46.502				
20	Schraube M6x16	40.171 1	40	Gummidämpfer	4	44.891
21	Blechschaube 3,5x16 DIN7981	44.161	41	Motorträger	1	44.950

Electronics switchbox

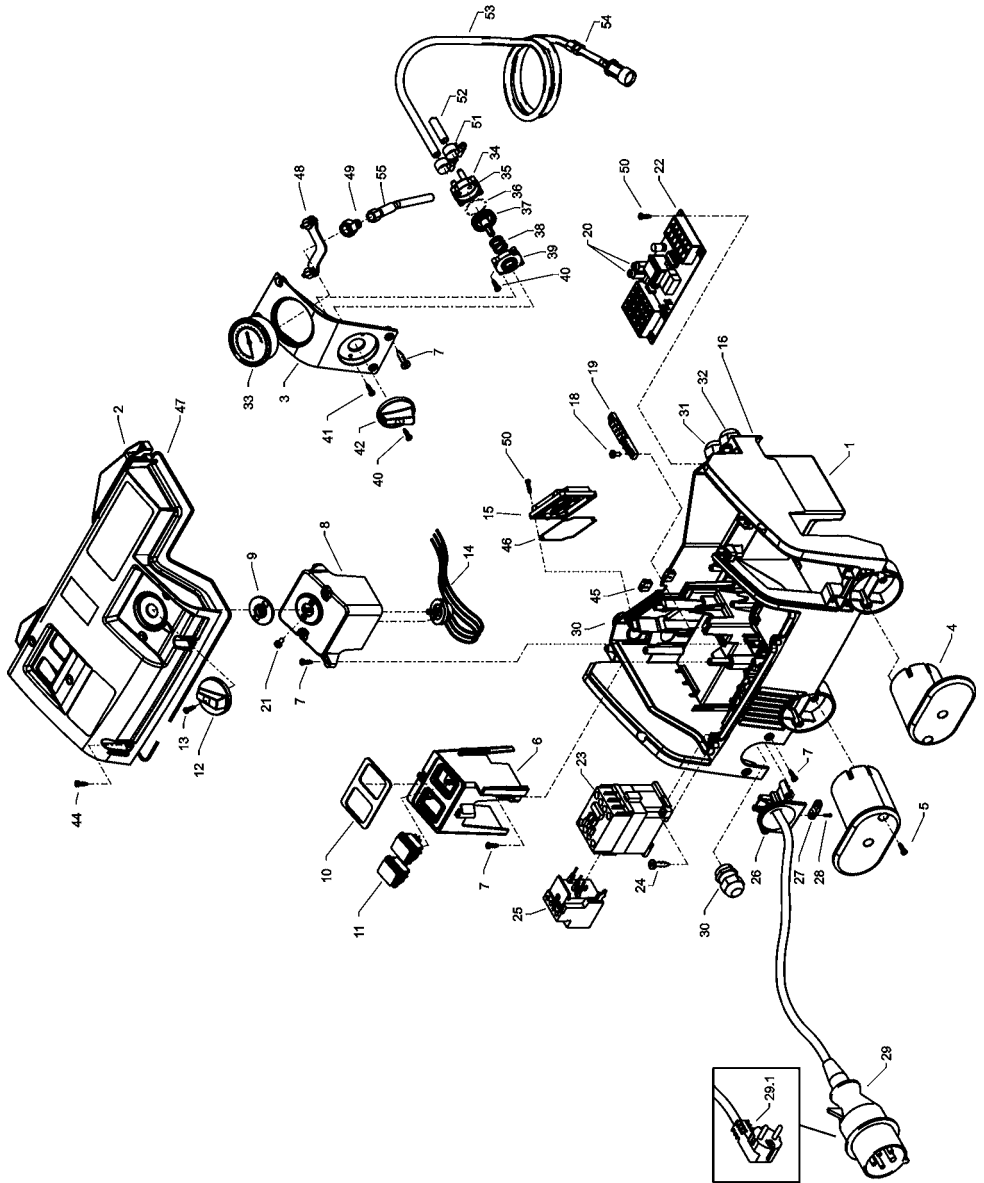

ESpare parts list KRÄNZLE therm CA Electronics switchbox

No.	Description	Qty.	Order No.	No.	Description	Qty.	Order No.
1	Elektrokasten	1	44.807 1	28	Schraube 3,5 x 14	2	44.525
2.1	Deckel für Elektrokasten therm CA 11/130.1	1	44.808 6	29	Netzanschlussleitung Drehsstrom	1	44.036
2.2	Deckel für Elektrokasten therm CA 12/150.1	1	44.808 7		8,0m, 4x 1,5 mm ² , H07RNF		
2.3	Deckel für Elektrokasten therm CA 15/120.1 mit Dichtung	1	44.808 8	29.1	Netzanschlussleitung Wechselstrom 5,75m, 3x 1,5 mm ² , H07RNF	1	41.092
3	Frontplatte Manometer	1	44.809 1	30	PG16-Verschraubung 1 Durchführung	2	41.419 1
4	Kabelaufwicklung	2	44.822	31	PG16-Verschraubung 2 Durchführungen	1	44.132
5	Schraube 5 x 25	4	41.414 1	32	PG16-Verschraubung 3 Durchführungen	1	44.133
6	Bock für Schalter	1	44.810	33	Manometer	1	15.039 1
7	Schraube 5x14	10	43.426	34	Gehäuse Waschmittelventil	1	44.145
8	Bock für Thermostat	1	44.811	35	O-Ring 5 x 1,5 (Viton)	1	44.150
9	Dichtung für Thermostat	1	44.818	36	O-Ring 28,24 x 2,62	1	44.149
10	Dichtung für Schalter	1	44.817	37	Regulierkolben Chemieventil	1	44.147
11	Schalter	2	44.835	38	Edelstahlfeder 1,8 x 15 x 15	1	44.148
12	Drehgriff Thermostat	1	44.153	39	Deckel für Chemieventil	1	44.146
13	Gewindeschneidschraube M 2,5 x 8	1	44.168	40	Blechschrabe 3,5 x 16	3	44.161
14	Thermostat drehbar elektronisch	1	44.951 1	41	Blechschrabe 3,5 x 19	2	44.162
15	Deckel für Übertemperaturauflöser	1	44.182	42	Drehgriff Chemieventil mit Blendkappe	1	44.151
16	PG16 – Blindstopfen	2	44.890	44	Schraube 5,0 x 20 mit angepr. Scheibe	10	43.018
18	Schraube 4,0 x 16	8	43.417	45	Durchführungsstülle	2	44.823
19	Erdungsklemme	1	44.839	46	Dichtung für Deckel Übertemp.	1	44.182 1
20	Feinsicherung M 1,25 A	1	44.676	47	Dichtung Elektrokrasten	1	44.838
20.1	Feinsicherung M 2,5 A	1	44.889 2	48	Klemmbügel für Manometer	1	44.049
21	Schraube M4x8 DIN84	2	46.604 1	49	Anschlussmuße Manometer	1	44.136
22	Steuerplatine 230 V / 50/60 Hz	1	44.952	50	Kunststoffschrabe 4,0 x 25	8	43.425
23	Schütz 400 V / 50/60 Hz	1	46.005 1	51	Schlauchklemme 9 - 9	2	44.054
23.1	Schütz 230 V / 50/60 Hz	1	46.005	52	Schlauch für Waschmittelansaugung	1	44.055
24	Schraube 4,0 x 25 mit angepr. Scheibe	2	43.425	53	Schlauch mit Filter und Rückschlagv.	1	44.056 1
25	Überstromauflöser 7,2-10A	1	42.641 1	54	Rückschlagventil für Waschmittelans.	1	44.240 1
25.1	Überstromauflöser 11,3-16A	1	42.641	55	Druckmeßleitung	1	44.102
26	Kabeltrompete mit Zugentlastung	1	44.819 1				
27	Zugentlastungsschelle	1	43.431		Chemieventil kpl. Pos. 34-42		44.052

Water supply and brake

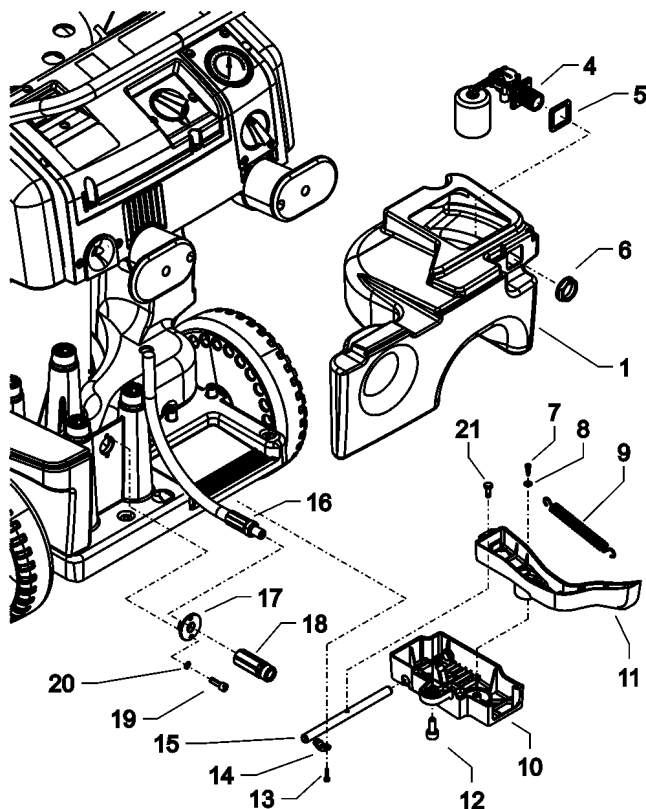

No.	Description	Qty.	Order No.
1	Wassertank	1	44.805 1
4	Schwimmerventil	1	46.250
5	Moosgummidichtung	1	46.261
6	Mutter R3/4"	1	46.258
7	Kunststoffschraube 5x14	1	43.426
8	Scheibe 5,3 DIN9021	1	50.152
9	Zugfeder	1	46.020
10	Deckel Bremse	1	46.016
11	Hebel Bremse	1	44.804
12	Zylinderschraube M 8 x 20	1	41.480
13	Innensechskantschraube M4x10	4	46.002
14	Schelle	2	43.431
15	Bolzen für Bremse	1	46.018
16	HD-Schlauch Wasserausgang	1	44.840
17	Haltescheibe	1	44.841
18	Ausgangsteil R1/4" x ST30	1	44.855
19	Schraube DIN912 M5x12	2	41.019 4
20	Zahnscheibe 5,1	2	43.483
21	Bundschraube	1	46.019
	Brake compl. Pos.7-15		44.880

Fuel supply

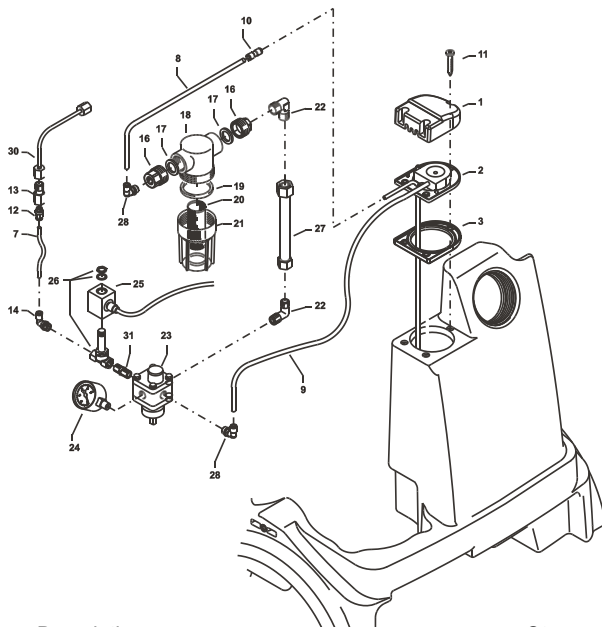

No.	Description	Qty.	Order No.
1	Deckel Brennstoffversorgung	1	44.011
2	Flansch mit Brennstoffleitungen	1	44.842
3	Gummidichtung	1	44.012
7	PA-Schlauch DN6	0,4 m	44.403
8	PA-Schlauch DN6	0,3 m	44.403
9	PA-Schlauch DN6	0,4 m	44.403
10	Steckverbinder 6 - 6	1	44.404
11	Schraube 5,0 x 25	3	41.414 1
12	Steckverbinderstutzen 1/8" x 6	1	44.407
13	Ermeto-Verschraubung R1/8" x 6L	1	44.372
14	Steckverbinderwinkel 1/8" x 6	1	44.408
16	Anschlussstück Brennstofffilter R1/4"	2	44.214
17	Gummidichtung 3/4"	2	41.047 1
18	Filtergrundkörper	1	13.301
19	Gummidichtung	1	13.303
20	Siebkörper Brennstofffilter	1	44.213
21	Filterbecher	1	13.302
22	Einschraubwinkel R1/4" AG x 10L	2	40.121 1
23	Brennstoffpumpe mit Magnetventil (Pos. 23, 26, 31)	1	44.852
24	Brennstoffmanometer 0-15 bar R1/8"	1	44.082
25	Magnetspule für Magnetventil	1	44.892
26	Magnetventil	1	44.251
27	Abstandsrohr 128 mm	1	44.084
28	Steckverbinderwinkel 1/4" x 6	1	44.405
30	Brennstoffzuleitung	1	44.845 1
31	Doppelnippel 1/4" x 1/4"	1	44.251 2
Fuel filter compl. Pos. 15 - 21			44.881
Fuel pump compl. Pos. 22-26, 28, 29 ,31			44.852 1

Combustion chamber

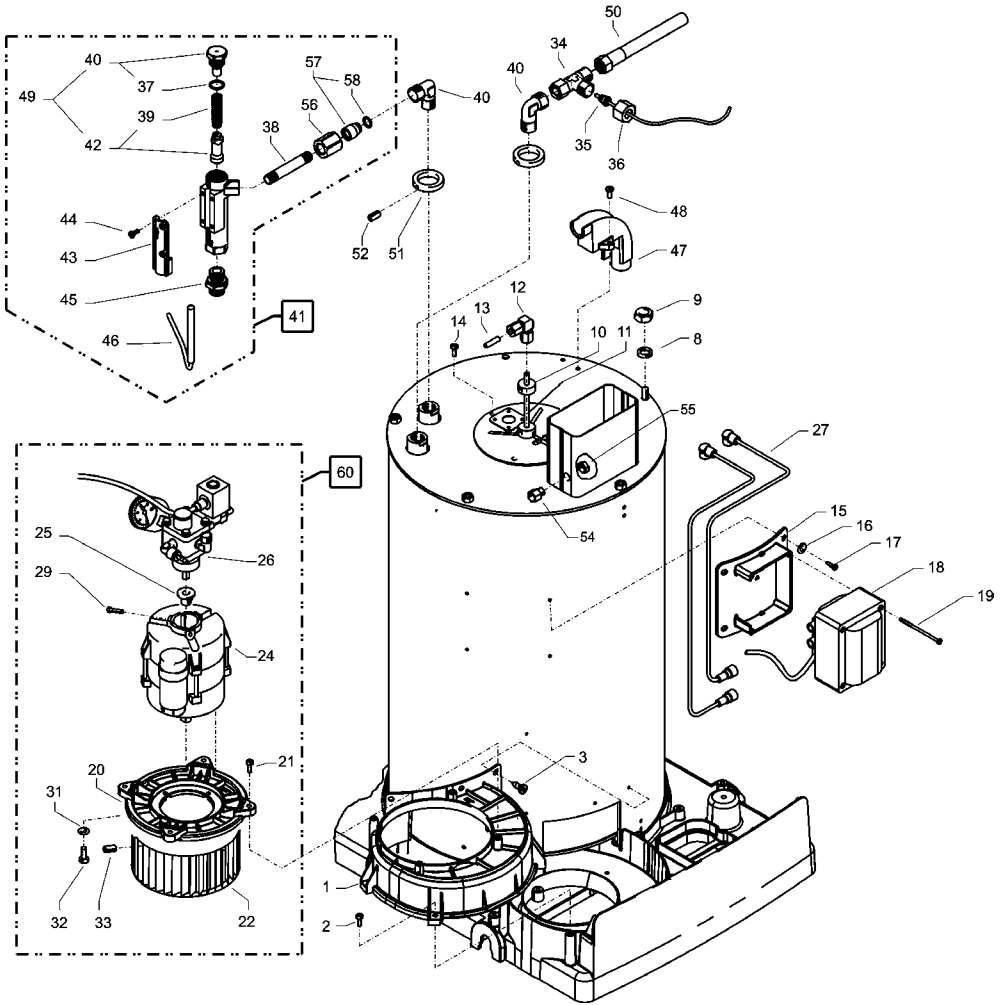

Spare parts list KRÄNZLE therm CA Combustion chamber

No.	Description	Qty.	Order No.
1	Gebläsegehäuse	1	44.802
2	Schraube M 5 x 10	5	43.021
3	Schraube 3,9 x 9,5	3	41.079
8	Federring A 8	5	44.222
9	Edelstahlmutter M 8	2	14.127 2
11	Brennstoffleitung „Düsenstock“ 115 mm	1	44.089 1
11.1	Brennstoffleitung „Düsenstock“ 120 mm (C 11/130)	1	44.089
12	Winkelverschraubung 6L x 6L	1	44.106
13	Brennstoffleitung Pumpe	1	44.845
14	Edelstahlschraube M 6 x 10	3	44.177
15	Halterung Zündtrafo	1	44.821
16	Scheibe DIN9021 4,3	4	43.472
17	Schraube 3,9 x 13	4	41.078
18	Zündtrafo 50 Hz	1	44.851
19	Schraube 4,0 x 60	4	43.420
20	Deckel Gebläsegehäuse	1	44.803
21	Schraube 4,8 x 16	4	40.282
22	Lüfterrad	1	44.847
24	Gebläsemotor 200-240 V / 50/60 Hz, DR rechts	1	44.850 6
25	Steckkupplung	1	44.852 2
26	Brennstoffpumpe kpl.	1	44.852 1
27	Hochspannungszündkabel	1	44.114
29	Zyl.schraube mit ISK M 5 x 12 DIN 912	1	40.134
31	Fächerscheibe 4,3	4	43.471
32	Schraube M 4 x 10	4	43.470
33	Gewindestift M 6 x 8 DIN 914	1	44.090
34	L-Verschraubung	1	44.869
35	Temperaturfühler	1	44.954
36	Ermetomutter 12 mm	2	40.075
37	O-Ring 14 x 2	1	43.445
38	Ermetorohr 12x85 mit 2x M12 x 1	1	44.848 1
39	Druckfeder Strömungswächter	1	14.217
40	Einschraubwinkelversch. 3/8" x 12L	2	44.092
41	Strömungswächter kpl.	1	12.610
42	Strömungskörper mit Zapfen für Feder	1	14.218
43	Abdeckung	1	12.603
44	Schraube M 4 x 8	4	44.216
45	Eingangsteil 3/8" x 12 mit Mutter und Schneidring	1	12.604
46	Magnetschalter	1	40.594 1
47	Schlauchführung	1	44.830
48	Schraube M 5 x 14	2	40.536
49	Strömungskörper incl. Stopfen und Feder	1	14.218 1
50	Hochdruckschlauch Wasserausgang	1	44.840
51	Abschlussring	2	44.086
52	Gewindestift M 6 x 8 DIN 914	2	44.090
54	Fühler Muffe	1	44.171
55	Mutter	1	44.172
56	Überwurfmutter	4	12.636
57	Nippel	4	12.637
58	O-Ring 9,5 x 2	4	12.635
60	Gebläse-Brennstoffpumpeneinheit Pos. 20-26, 28-33	1	44.882

Combustion chamber

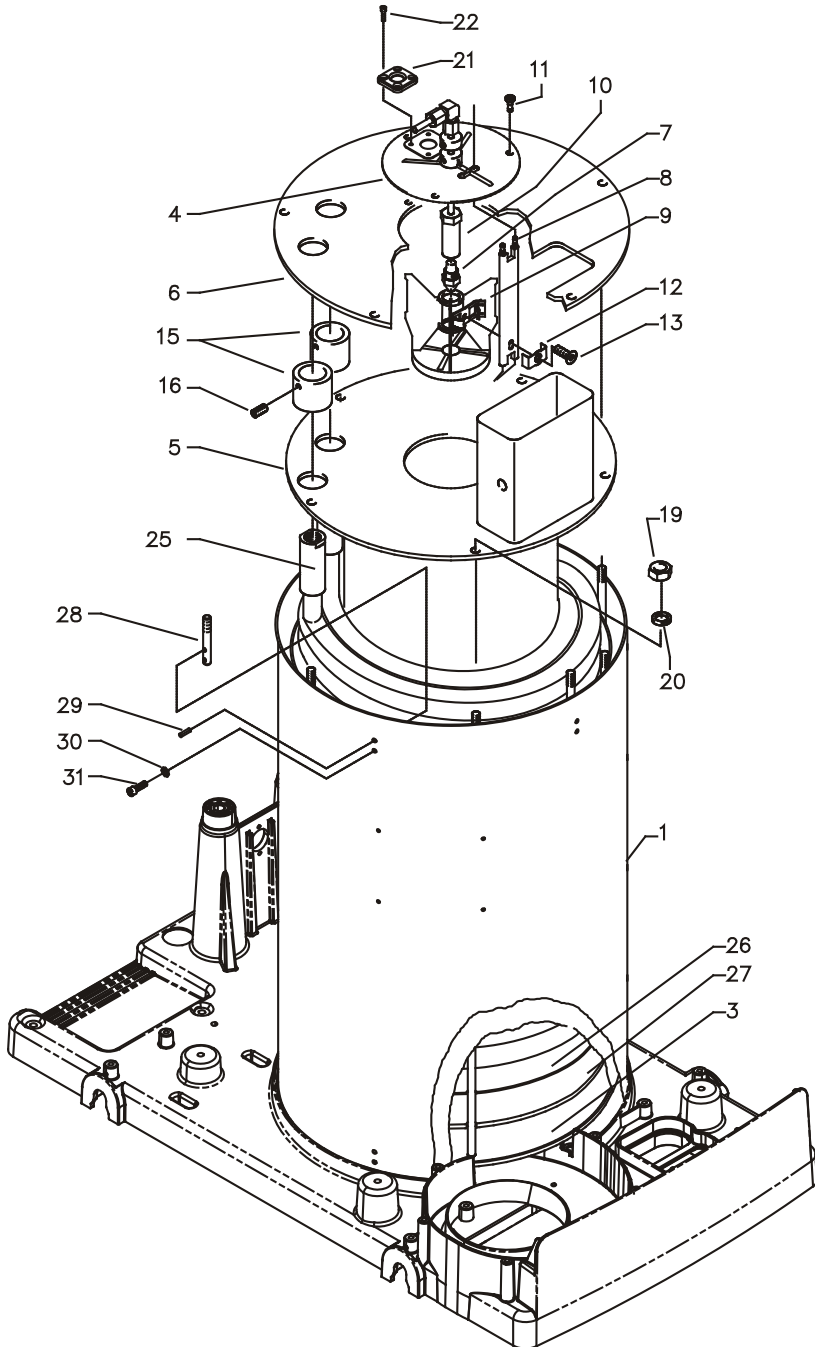

Spare parts list KRÄNZLE therm CA Combustion chamber

No.	Description	Qty.	Order No.
1	Außenmantel mit Zugbolzen	1	44.860
3	Innenmantel mit Bodenplatte	1	44.064 1
4	Deckel Düsenstock	1	44.079
5	Innendeckel mit Kamin und Flammrohr	1	44.861
6	Außendeckel	1	44.862
7	Brennstoffdüse 60° B 1,35 gph (CA 11/130; CA 12/150)	1	44.077 2
7.1	Brennstoffdüse 60° B 1,5 gph (CA 15/120)	1	44.077
8	Blockelektrode	1	44.854
9	Düsenstock Ø 25 mm, 6 Schl.	1	44.076 4
10	Düsenhalter	1	44.078
11	Edelstahlschraube M 6 x 10	3	44.177
12	Klemmblech für Elektrode	1	44.076 1
13	Zyl.schraube mit ISK M 5 x 15 DIN6912	1	44.076 2
15	Abschlusschülse	2	44.081
16	Schraube M 6 x 12 DIN 933	2	44.090 1
19	Edelstahlmutter M 8	7	14.127 2
20	Federring A 8	7	44.222
21	Schauglas	1	44.258
22	Schraube M 4 x 12 DIN7985	4	41.489
25	Heizschlange	1	44.900
27	Isolationsplatte	1	44.360
28	Zugbolzen	10	44.863
29	Spannstift 4 x 14	10	44.829
30	Zahnscheibe 4,3	10	43.471
31	Schraube DIN912 M 4 x 10	10	46.002

Unloader and pressure switch

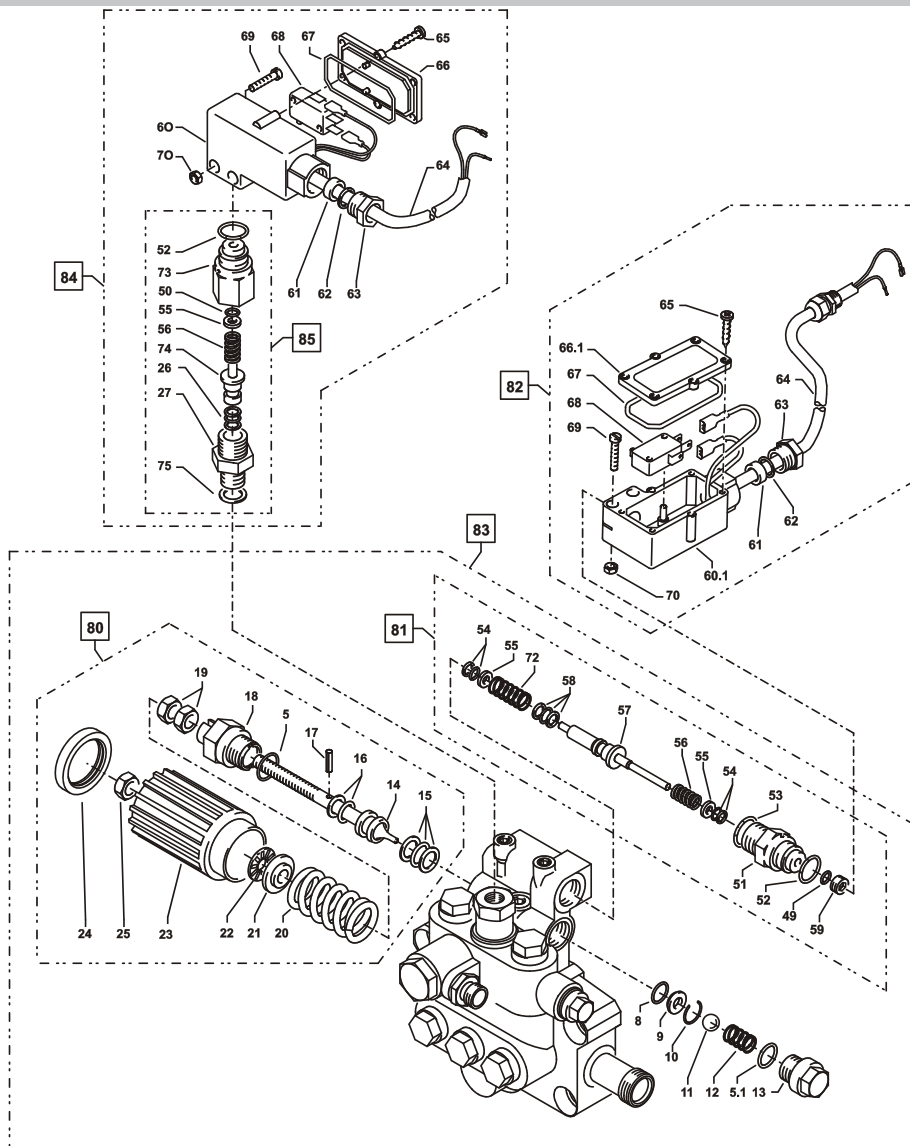

No.	Description	Qty.	Order No.
80	Steuerkolben kpl.		40.490
81	Ausgangsstück für Schalter rot kpl.		15.009 3
82	Druckschalter (rot) kpl. mit Kabel 0,49 m		44.120 1
83	Ventilgehäuse kpl.		44.320
84	Druckschalter (schwarz) kpl. mit Kabel 0,59 m		44.120
85	Ausgangsstück für Schalter schwarz kpl.		15.011 1

Spare parts list KRÄNZLE therm CA Unloader and pressure switch

No.	Description	Qty.	Order No.
5	O-Ring 16 x 2	1	13.150
5.1	O-Ring 13,94 x 2,62	1	42.167
8	O-Ring	1	12.256
9	Edelstahlsitz	1	14.118
10	Sicherungsring	1	13.147
11	Edelstahlkugel 8,5 mm	1	13.148
12	Edelstahlfeder	1	14.119
13	Verschlussschraube	1	14.113
14	Steuerkolben	1	14.134
15	Parbaks 16 mm	1	13.159
16	Parbaks 8 mm	1	14.123
17	Spannstift	1	14.148
18	Kolbenführung spezial	1	42.105
19	Mutter M 8 x 1	2	14.144
20	Ventilfeder schwarz	1	14.125
21	Federdruckscheibe	1	14.126
22	Nadellager	1	14.146
23	Handrad	1	40.457
24	Kappe Handrad	1	40.458
25	Elastic-Stop-Mutter	1	14.152
26	Parbaks 7 mm	1	15.013
27	Ausgangsteil R1/4" AG	1	15.011
49	O-Ring 3,3 x 2,4	1	12.136
50	O-Ring 5 x 1,5	1	15.014
51	Führungsteil Steuerstößel	1	15.009 1
52	O-Ring 12,3 x 2,4	2	15.017
53	O-Ring 14 x 2	1	43.445
54	Parbaks 4 mm	3	12.136 2
55	Stützscheibe dm 5	1	15.015
55.1	Stützscheibe dm 4	2	15.015 1
56	Edelstahlfeder	1	15.016
57	Steuerstößel lang	1	15.010 2
58	Parbaks	1	15.013
59	Stopfen M10x1 (durchgebohrt)	1	13.385 1
60	Gehäuse Elektroschalter (schwarz)	1	15.007
60.1	Gehäuse Elektroschalter (rot)	1	15.007 1
61	Gummimanschette PG 9	1	15.020
62	Scheibe PG 9	1	15.021
63	Verschraubung PG 9	1	15.022
64	Kabel 2 x 1,0 mm ² 1,10 m grau	1	44.871
64.1	Kabel 2 x 1,0 mm ² 1,10 m schwarz	1	44.235
65	Blechschrabe 2,9 x 16	6	15.024
66	Deckel Elektroschalter (schwarz)	1	15.008
66.1	Deckel Elektroschalter (rot)	1	15.008 1
67	O-Ring 44 x 2,5	1	15.023
68	Mikroschalter	1	44.262
69	Zylinderschraube M 4 x 20	2	15.025
70	Sechskant-Mutter M 4	2	15.026
72	Druckfeder 1 x 8,6 x 30	1	40.520
73	Grundteil Elektroschalter	1	15.009
74	Steuerkolben	1	15.010
75	Aluminium-Dichtring	2	13.275 1

Safety valve for heating coil

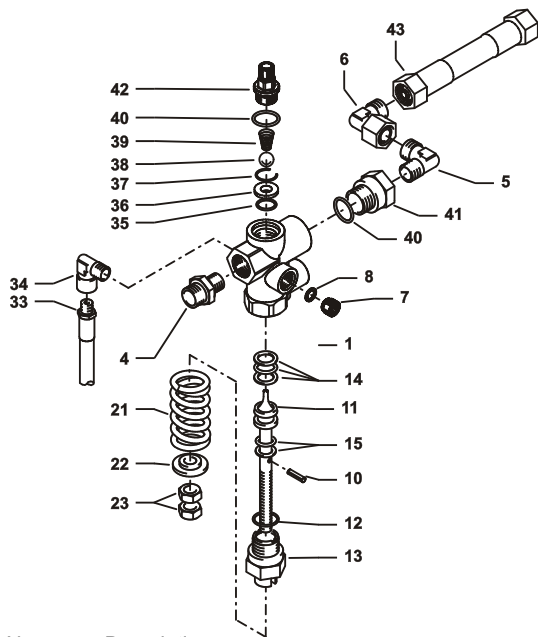

Safety valve for heating coil
 (Adjustment must be approx. 15% above the operating pressure)

No.	Description	Qty.	Order No.
1	Ventilkörper	1	14.145
4	Ermetoverschraubung R 3/8" x 12 mm	1	40.076
6	Ermetowinkel 12 mm x 12 mm Mutter	1	44.865
7	Stopfen R1/4"	1	13.387
8	O-Ring	1	13.275
10	Spannstift	1	14.148
11	Steuerkolben	1	14.133
12	O-Ring	1	13.150
13	Kolbenführung	1	14.130
14	Parbaks 16 mm	1	13.159
15	Parbaks 8 mm	1	14.123
21	Ventilfeder	1	14.125
22	Federdruckscheibe	1	14.126
23	Sechskantmutter M 8 x 1	2	14.144
33	Rücklaufschlauch S200	1	44.867
34	Einschraubwinkel	1	40.121
35	O-Ring 11 x 1,44	1	12.256
36	Edelstahlsitz	1	14.118
37	Sprengtring	1	13.147
38	Edelstahlkugel 8,5 mm	1	13.148
39	Edelstahlfeder	1	14.119
40	O-Ring 15 x 2	2	13.150
41	Eingangsstück M20x1,5" x R1/4"	1	13.136 1
42	Anschlussstück Druckmessleitung	1	44.868
43	Verbindungsschlauch 12mm S200-Strömungw.	1	44.866

Guide piston compl. Pos. 10-15; 21-23

14.110 1

Safety valve compl. Pos. 1-15; 21-42

44.888

Pump

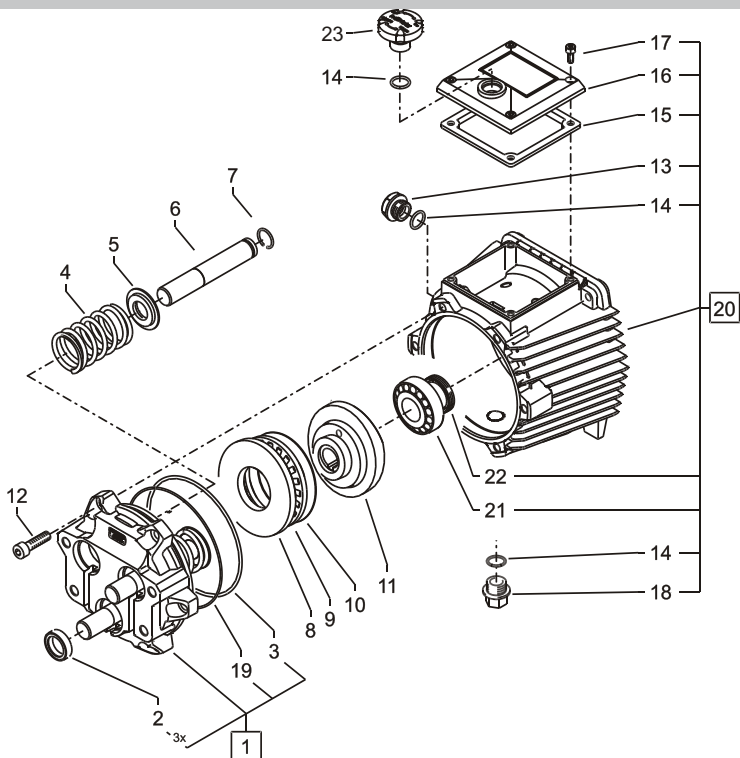

No.	Description	Qty.	Order No.
1	Gehäuseplatte mit Dichtungen	1	40.471
2	Öldichtung 18 x 28 x 7	3	41.031
3	O-Ring 113,97 x 2,62	1	40.474
4	Plungerfeder	3	40.453
5	Federdruckscheibe	3	40.454
6	Plunger 18mm (AM-Pumpe)	3	40.455
7	Sprengring	3	41.035
8	Wellenscheibe	1	40.043
9	Axial-Rollenkäfig	1	40.040
10	AS-Scheibe	1	40.041
11.1	Taumelscheibe 9,0° (therm CA 11/130)	1	40.473-9,0
11.2	Taumelscheibe 9,85° (therm CA 12/150)	1	40.473-9,85
11.3	Taumelscheibe 12,5° (therm CA 15/120)	1	40.473-12,5
12	Schraube DIN912 M 8 x 30	6	41.036 3
13	Ölschauglas	1	42.018 1
14	O-Ring 14 x 2	3	43.445
15	Dichtung Öldeckel	1	41.019 3
16	Öldeckel	1	41.023 1
17	Schraube DIN912 M 5 x 12	4	41.019 4
18	Verschlussstopfen R 3/8"	1	40.051
19	O-Ring 98 x 1,5	1	40.475
20	Ölgehäuse kpl.	1	40.470 1
21	Motor-Lager Kegelrollenlager 31304	1	40.472
22	Öldichtung 25 x 35 x 7	1	41.024
23	Öleinfüllschraube	1	43.819

Valve housing

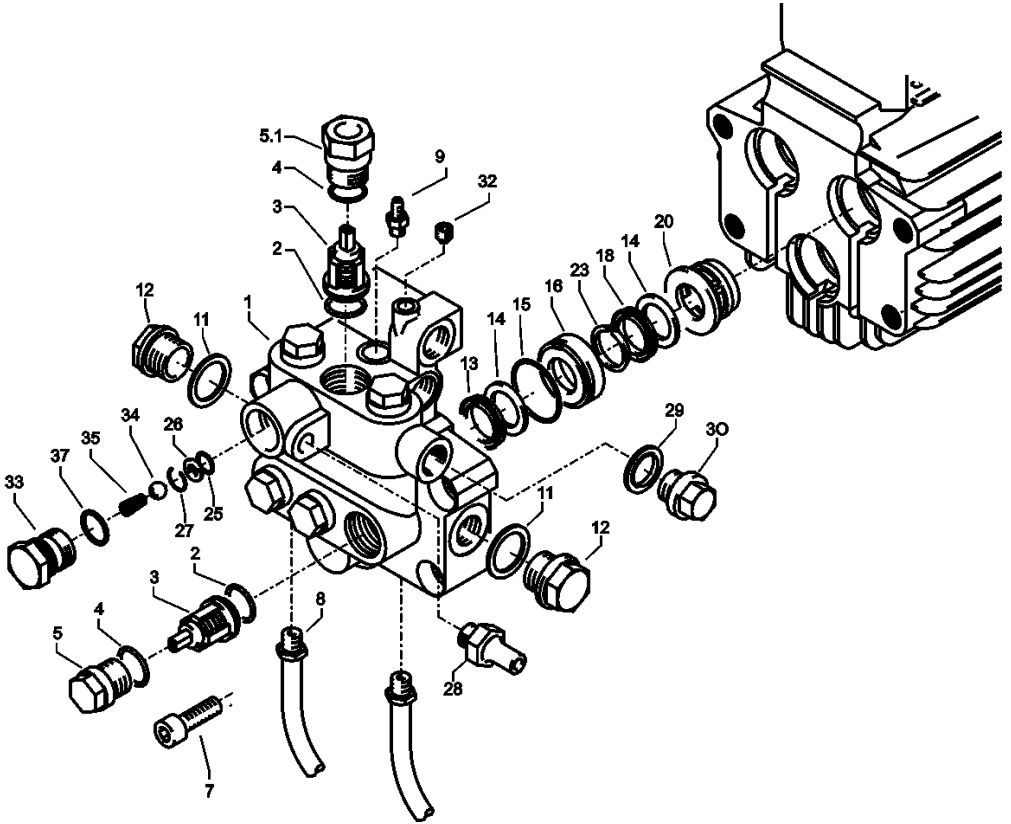

Spare parts list KRÄNZLE therm CA Valve housing AM for plunger diameter 18 mm

No	Description	Qty.	Ord.-No
1	Ventilgehäuse AM-Pumpe	1	40.451
2	O-Ring 15 x 2	6	41.716
3	Ventile (grün) für APG-Pumpe	6	41.715 1
4	O-Ring 16 x 2	6	13.150
5	Ventilstopfen	5	41.714
5.1	Ventilstopfen mit Druckteil	1	42.106
7	Innensechskantschraube M10 x 35	4	42.509 1
8	Ansaugschlauch mit Nippel R1/4"	2	44.096 4
9	Saugzapfen Schlauchanschluss	1	13.236
11	Dichtring	1	40.019
12	Stopfen 3/8"	1	40.018
13	Manschette 18 x 26 x 4/2	3	41.013
14	Backring 18 mm	6	41.014
15	O-Ring	3	40.026
16	Leckagering 18 mm	3	41.066
18	Gewebemanschette 18 x 26 x 5,5/3	3	41.013 1
20	Zwischenring 18 mm	3	41.015 2
23	Druckring	3	41.018
25	O-Ring 11 x 1,5	1	12.256
26	Edelstahlsitz Ø 7	1	14.118
27	Sprengring	1	13.147
28	Ausgangsteil Pumpe R1/4" x 12	1	44.897
29	Kupferring	1	42.104
30	Dichtstopfen R1/4" mit Bund	1	42.103
32	Dichtstopfen M 8 x 1	2	13.158
33	Ausgangsteil	1	40.522
34	Edelstahlkugel Ø10	1	12.122
35	Rückschlagfeder „K“	1	14.120 1
37	O-Ring 18 x 2	1	43.446

Ventilgehäuse kpl.

44.320

Rep.-kit valves for APG-pump

41.748 1

consisting of: 6x Pos. 4; 6x Pos. 5; 6x Pos. 6

Repair kit sleeves 18 mm

41.049 1

consisting of: 3x Pos. 27; 3x Pos. 28;
 3x Pos. 28.1; 6x Pos. 29; 3x Pos. 30

Pump motor

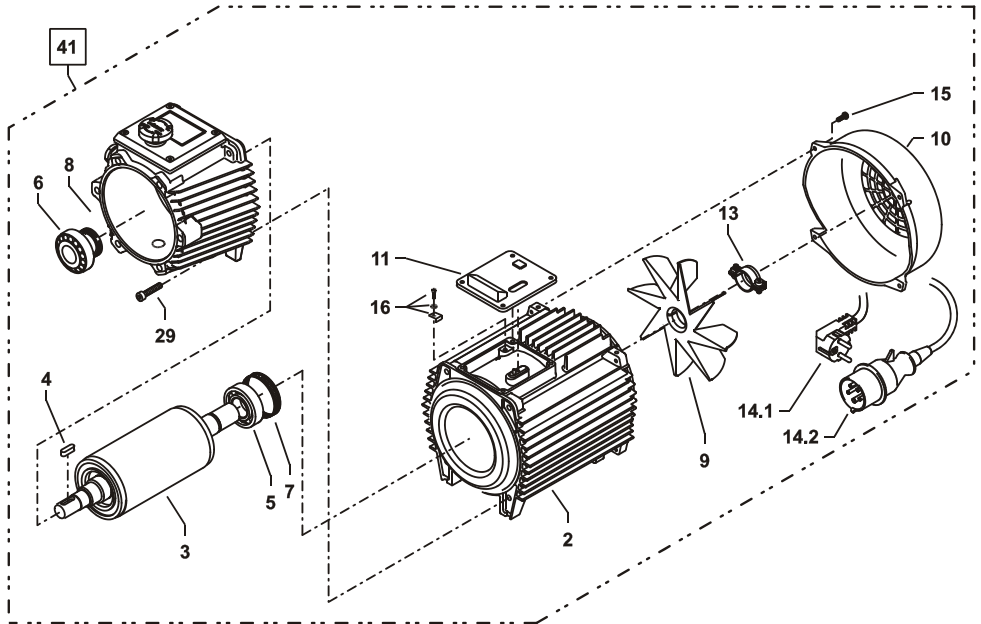

No.	Description	Qty.	Order No.
2.1	Motorgehäuse mit Stator Wechselstrom	1	43.826
2.2	Motorgehäuse mit Stator Drehstrom	1	43.827
3	Rotor mit Motorwelle	1	43.316
4	Passfeder 6 x 6 x 20	1	41.483 1
5	Motor-Lager B-Seite 6205 - 2Z	1	43.317
6	Motor-Lager Kegelrollenlager 31304	1	40.472
7	Toleranzhülse	1	43.330 1
8	Öldichtung 25 x 35 x 7	1	41.024
9	Lüfterrad BG 90	1	43.319
10	Lüfterhaube BG 90	1	43.320
11	Flachdichtung	1	43.030
12	Innensechskantschraube M 6 x 30	4	43.037
13	Schelle für Lüfterrad mit Schrauben	1	43.454
14.1	Kabel mit Stecker (Schuko)	1	41.092
14.2	Kabel mit Stecker (CE-KON)	1	43.828
16	Erdungsschraube kpl.	1	43.038
41.1	Motor Wechselstrom 230V / 50Hz kpl. ohne Schalter Pos. 1 - 16		43.867
41.2	Motor Drehstrom 400V / 50Hz kpl. ohne Schalter Pos. 1 - 16		43.868

Terminal box

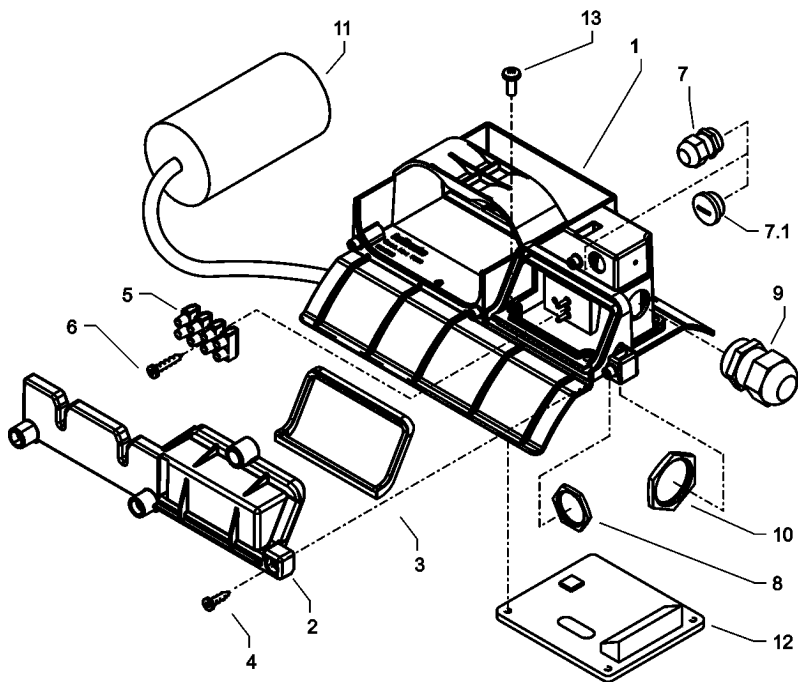

No.	Description	Qty.	Order No.
1	Klemmkasten	1	44.814
2	Deckel Klemmkasten	1	44.815
3	Dichtung Deckel	1	44.816
4	Schraube 5,0 x 14	3	43.426
5	Kunststoffschraube 3,5 x 20	2	43.415
6	Lüsterklemme 5-pol.	1	43.326 1
7	PG9-Verschraubung (CA 11/130)	1	43.034
7.1	PG9-Verschlussstopfen (CA12/150)	1	44.142
8	PG9-Gegenmutter	1	41.087 1
9	PG16-Verschraubung	1	41.419 1
10	PG16-Gegenmutter	1	44.119
11	Kondensator 70 µF	1	43.322
12	Flachdichtung	1	43.030
13	Schraube M 4 x 12	4	41.489

Terminal box compl. 2.3 kW 230V / 50Hz

44.886

Terminal box compl. 4.8 kW, 3~ 400V / 50Hz

44.887

Hose drum

(Special accessory)
Upgrade kit: 44.152 2

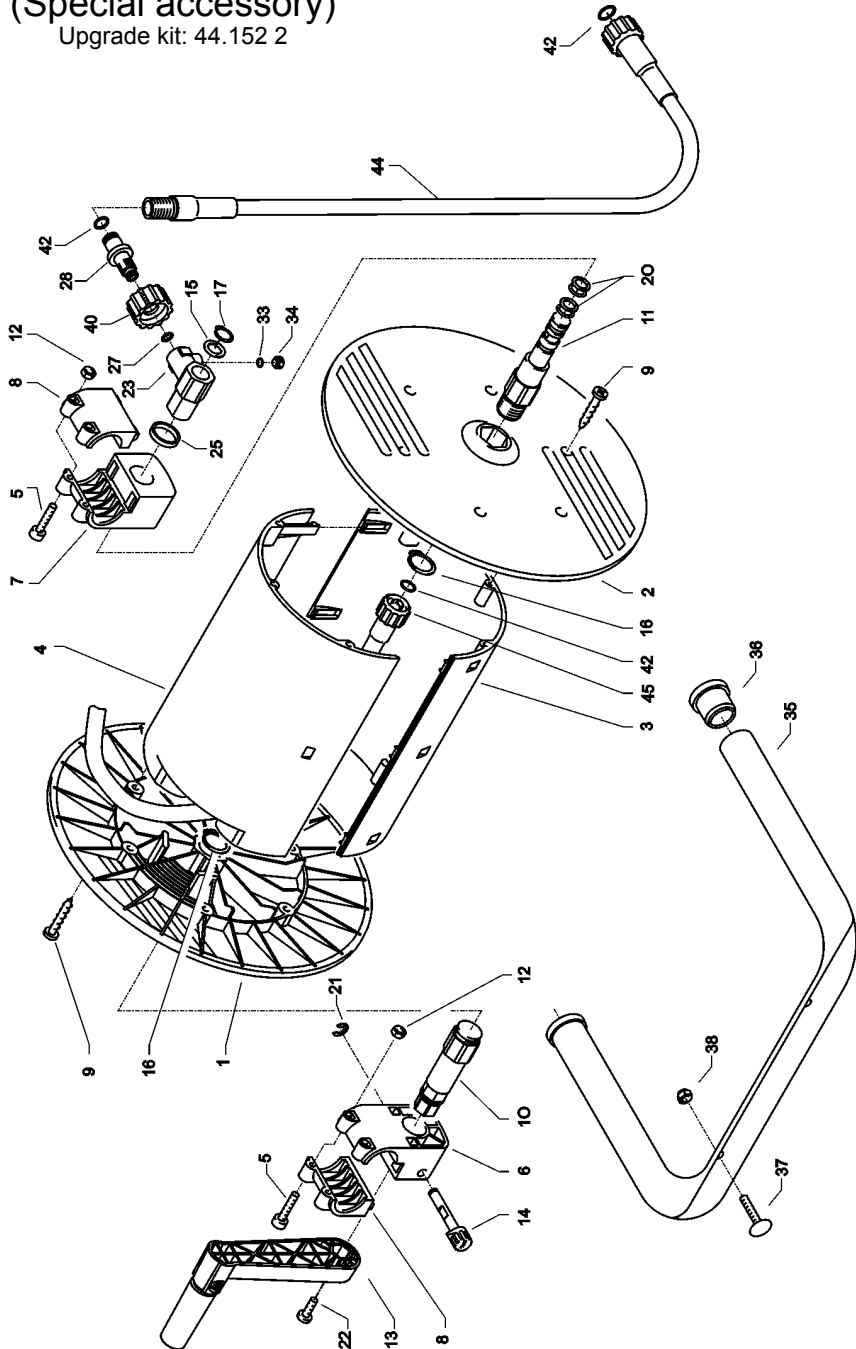

Spare parts list KRÄNZLE therm CA Hose drum

No.	Description	Qty.	Order No.	No.	Description	Qty.	Order No.
1	Seitenschale Schlauchführung	1	40.302	35	Haltebügel	1	44.143
2	Seitenschale Wasserführung	1	40.301	36	Gummistopfen	2	40.208 1
3	Trommel Unterteil	1	40.304	37	Schlossschraube M 8 x 35	2	41.408
4	Trommel Oberteil	1	40.303	38	Elastic-Stop-Mutter M 8	2	41.410
5	Innensechskantschraube M 4 x 25	4	40.313	40	Überwurfmutter	1	13.276 2
6	Lagerklotz mit Bremse	1	40.306	42	O-Ring 9,3 x 2,4	4	13.273
7	Lagerklotz links	1	40.305	44	Verbindungsschlauch NW 8	1	44.160
8	Klemmstück	2	40.307	45	Hochdruckschlauch NW 8	15 m	44.879
9	Kunststoffschraube 5,0 x 20	12	43.018				
10	Antriebswelle	1	40.310				
11	Welle Wasserführung	1	40.311				
12	Elastic-Stop-Mutter M 4	4	40.111				
13	Handkurbel klappbar	1	40.320 0				
14	Verriegelungsbolzen	1	40.312				
15	Scheibe MS 16 x 24 x 2	1	40.181				
16	Wellensicherungsring 22 mm	2	40.117				
17	Wellensicherungsring 16 mm	1	40.182				
20	Parbaks 16 mm	2	13.159				
21	Sicherungs Scheibe 6 DIN6799	1	40.315				
22	Schraube M 5 x 10	1	43.021				
23	Drehgelenk	1	40.167				
25	Distanzring	1	40.316				
27	O-Ring 6,86 x 1,78	1	40.585				
28	Anschlussstück	1	40.308				
33	O-Ring 6 x 1,5	1	13.386				
34	Stopfen M 10 x 1	1	13.385				
					Hose drum compl.		41.259
					without hose, without bracket		
					Bracket compl.		44.143 1
					consisting of: Pos. 35 - 38		
					Crank compl.		40.309 9
					consisting of: Pos. 51 - 57		

Gun

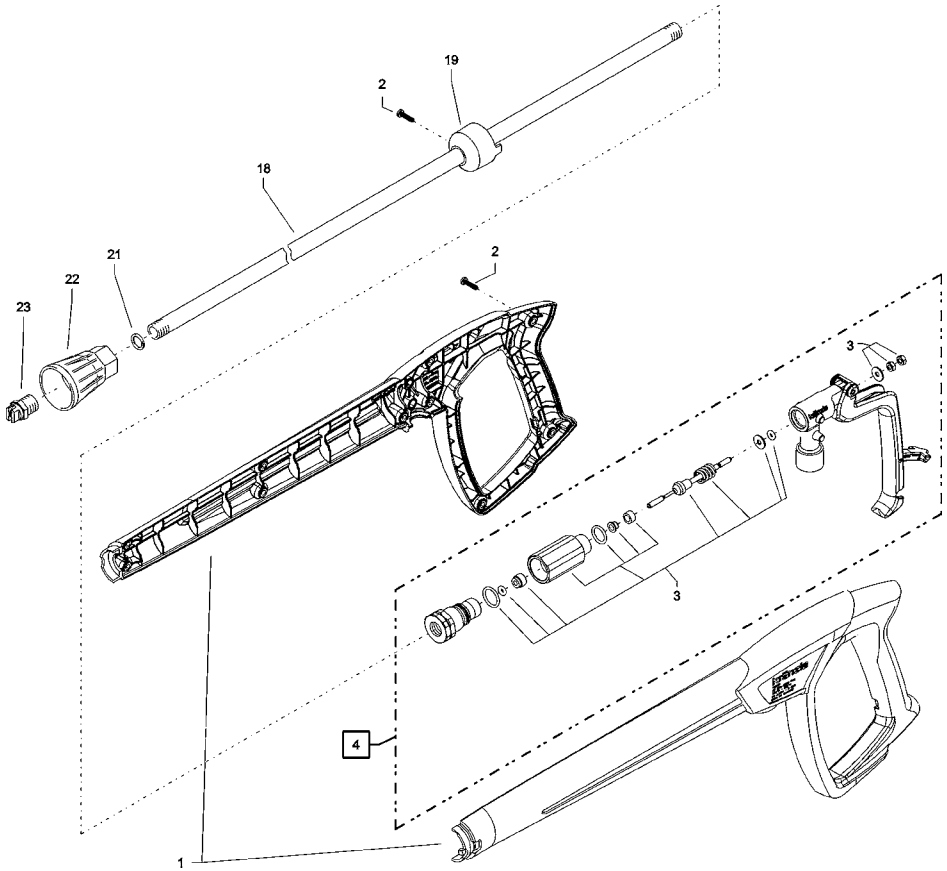

No.	Description	Qty.	Order No.
1	Pistolenschale re+li	1	12.450
2	Schraube 3,5 x 14	10	44.525
3	Reparatursatz M2000		12.454
4	M2000 Grundbaugruppe	1	12.458
18	Rohr 950 mm; bds. R1/4"	1	15.004 4
19	Abschlussring	1	12.457
21	Aluminium Dichtring 2mm	2	13.275 1
22	Düsenchutz	1	26.002
23	Flachstrahldüse 25045 (CA 11/130; CA 12/150)	1	D25045
23.1	Flachstrahldüse 2507 (CA 15/120)	1	D2507
M2000-Pistole einteilig mit Düsenchutz und HD-Düse 25045 (CA 11/130; CA 12/150)			12.486-D25045
M2000-Pistole einteilig mit Düsenchutz und HD-Düse 2507 (CA 15/120)			12.486-D2507

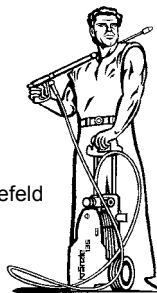

EC declaration of conformity

We hereby declare,
that the high pressure models:

Kränzle therm CA 11/130
Kränzle therm CA 12/150
Kränzle therm CA 15/120

(techn. documentation available from):

Manfred Bauer, Fa. Josef Kränzle
Rudolf-Diesel-Str. 20, 89257 Illertissen

Nominal flow:

K therm CA 11/130: 660 l/h
K therm CA 12/150: 720 l/h
K therm CA 15/120: 900 l/h

comply with the following guidelines
and specifications and their amend-
ments for high pressure cleaners:

machinery directive 2006/42/EEC,
EMV-directive 2004/108/EEC,
noise directive 2005/88/EC, Art. 13,
HP water spraying machines
annex 3, part B, chapter 27

Sound power level

measured: **CA 11/130: 88 dB (A); CA 12/150: 90 dB (A);**
CA 15/120: 90 dB (A);
guaranteed:: **CA 11/130: 90 dB (A); CA 12/150: 92 dB (A);**
CA 15/120: 92 dB (A);

Applied conformity evaluation procedures

annex V, noise directive 2005/88/EC

Applied specifications and
standards:

EN 60 335-2-79 :2009
EN 55 014-1 :2006
EN 55 014-2 / A2:2008
EN 61 000-3-2 : 2006
EN 61 000-3-3 : 2008

Bielefeld, den 29.02.12

Kränzle Josef
(Managing Director)

Inspection sheet

Customer

- All lines connected
- Hose clamps tight
- Screws all installed and tightened
- Ignition cable plugged in
- Visual check carried out
- Brake function checked

Leak test

- Water tank filled and checked
- Water inlet checked for tightness
- Float valve function checked
- Machine checked for tightness under pressure

Electrical check

Earth line checked

Current intake

Operating pressure

Switch-off pressure

Kränzle therm CA

Result of flue gas analysis

Steam phase checked

Chemical valve checked

Start/Stop automatic

Thermostat function checked

Burner function checked

Water inlet temperature

5	6	7	8	9	10	11	12	13	14	15
---	---	---	---	---	----	----	----	----	----	----

 °C

Water temperature reached

70	72	74	76	78	80	82	84	86	88	90
----	----	----	----	----	----	----	----	----	----	----

 °C

Fuel pressure

9	9,5	10	10,5	11	11,5	12	12,5	13	13,5	14
---	-----	----	------	----	------	----	------	----	------	----

 bar

Measured smoke spot number

0	1	2	3
---	---	---	---

Safety equipment sealed with lacquer

The appliance fulfills all requirements according to this inspection sheet

Name of inspector

Date

Signature

Inspection report for HP cleaners

Inspection report on annually carried out Labour Safety Inspection (UVV) according to the Guidelines for Liquid Spray Equipment. (This inspection sheet serves as proof for the completion of the retest and must be kept carefully!) Kränzle-Test Stamp Mark: Order Number UVV200106

Owner: Type **therm**:
 Address: Serial no.:
 Rep.-order-no.:

Scope of inspection:	ok	yes	no	repaired
Type plate (on hand)				
Operating manual (on hand)				
Protective covering, -device				
Pressure line (tightness)				
Pressure gauge (function)				
Float valve (tightness)				
Spraying device (marking)				
HP-hose/ connector (damage, marking)				
Safety valve opens at 10% / 20% excess				
Pressure reservoir				
Heating oil line (tightness)				
Solenoid valve (function)				
Thermostat (function)				
Flow controller (function)				
Power cable (damage)				
Power plug (damage)				
Protective conductor (connected)				
Emergency Off Switch (function)				
On/Off-switch				
Water quantity safety device (function)				
Used chemicals				
Allowed chemicals				

Inspection data	determ. value	set value
High-pressure nozzle		
Operating pressurebar		
Cutting-off pressure.....bar		
Smoke spot number.....acc. to Bacharach scale		
CO ² -value.....% CO ²		
Efficiency rating.....%		
Conductor resist. not exceeded / value:		
Insulation		
Leakage current:		
Gun locked		

Inspection result (tick)

- The appliance was checked by an expert according to the Guidelines for Liquid Spray Equipment, the defects found have been rectified so that the Labour Safety can be confirmed.
- The appliance was checked by an expert according to the Guidelines for Liquid Spray Equipment. The Labour Safety cannot be confirmed unless the defects found are rectified by repair or replacement of the faulty parts.
- The next retest according to the Guidelines for Liquid Spray Equipment has to be carried out by: Month Year

Place, Date Signature

Inspection report for HP cleaners

Inspection report on annually carried out Labour Safety Inspection (UVV) according to the Guidelines for Liquid Spray Equipment. (This inspection sheet serves as proof for the completion of the retest and must be kept carefully!) Kränzle-Test Stamp Mark: Order Number UVV200106

Owner: Type **therm**:
 Address: Serial no.:
 Rep.-order-no.:

Scope of inspection: ok yes no repaired

Scope of inspection:	ok	yes	no	repaired
Type plate (on hand)				
Operating manual (on hand)				
Protective covering, -device				
Pressure line (tightness)				
Pressure gauge (function)				
Float valve (tightness)				
Spraying device (marking)				
HP-hose/ connector (damage, marking)				
Safety valve opens at 10% / 20% excess				
Pressure reservoir				
Heating oil line (tightness)				
Solenoid valve (function)				
Thermostat (function)				
Flow controller (function)				
Power cable (damage)				
Power plug (damage)				
Protective conductor (connected)				
Emergency Off Switch (function)				
On/Off-switch				
Water quantity safety device (function)				
Used chemicals				
Allowed chemicals				

Inspection data determ. value set value

Inspection data	determ. value	set value
High-pressure nozzle		
Operating pressurebar		
Cutting-off pressure.....bar		
Smoke spot number.....acc. to Bacharach scale		
CO ² -value.....% CO ²		
Efficiency rating.....%		
Conductor resist. not exceeded / value:		
Insulation		
Leakage current:		
Gun locked		

Inspection result (tick)

- The appliance was checked by an expert according to the Guidelines for Liquid Spray Equipment, the defects found have been rectified so that the Labour Safety can be confirmed.
- The appliance was checked by an expert according to the Guidelines for Liquid Spray Equipment. The Labour Safety cannot be confirmed unless the defects found are rectified by repair or replacement of the faulty parts.
 The next retest according to the Guidelines for Liquid Spray Equipment has to be carried out by: Month Year

Place, Date Signature

Technix Rubber & Plastic Ltd
02242826
www.technix.ie
Kränzle — world-wide:
Technical perfection, top design.

kranzle®

w w w . k r a n z l e . c o m



Order No.: 30.702.1

Reprint only allowed with the authorization of **kranzle**®
As date of 18. 03. 2013